

SL series



Features

- Excellent noise reduction and filtering in dry condition.

Symbol

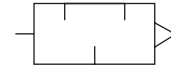

How to Order

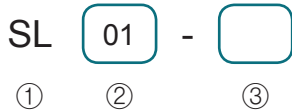

① Series

SL	Sintered silencer
----	-------------------

② Port size

M5	M5×0.8
01	R(PT) 1/8
02	R(PT) 1/4
03	R(PT) 3/8
04	R(PT) 1/2
06	R(PT) 3/4
08	R(PT) 1

③ Option

Nil	Hexagonal (Standard)
1	Circular
2	Circular (Short)

※ Only for SL01 series.

Specifications

Model	SLM5	SL01	SL02	SL03	SL04	SL06	SL08
Noise reduction dB(A)	10	14	18	22	22	23	22
Fluid	Compressed air						
Max. working pressure	10kgf/cm ² (1.0MPa)						
Ambient & fluid temperature	-10~180℃						
Effective area mm ²	8	18	40	60	115	210	290
Material	Sintered Bronze						
Filtration	60μm						
Weight (g)	3	8 Circular :14 Circular (short) :8	18	32	42	82	162

Structure

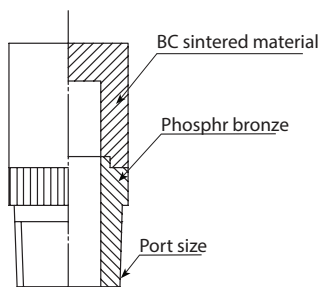

Dimensions

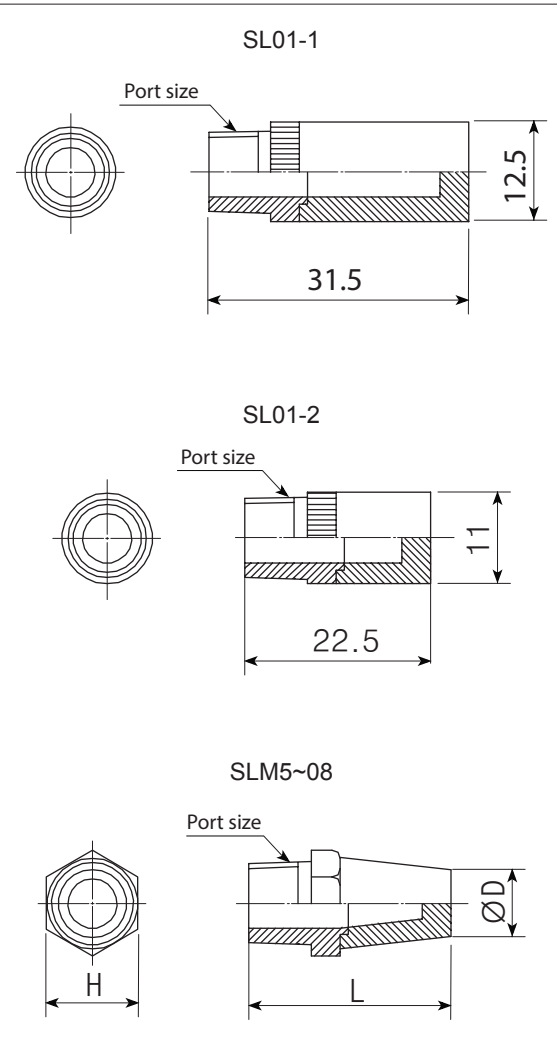

Model	Port size	D	H	L
SLM5	M5×0.8	6.5	7	18.5
SL01	R(PT) 1/8	8	11	24.5
SL02	R(PT) 1/4	11	14.5	34
SL03	R(PT) 3/8	13	19	39
SL04	R(PT) 1/2	16	22	44
SL06	R(PT) 3/4	18	28	54
SL08	R(PT) 1	24	35	81