

# ACM series

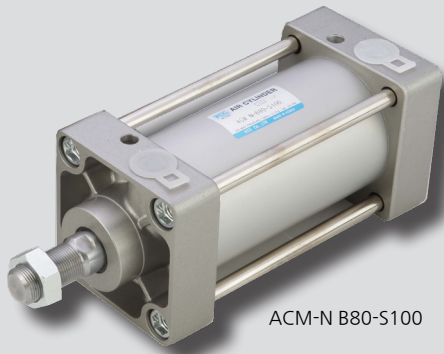

ACM-N B80-S100

### Features

- With built-in magnet (Standard)
- With non-lubricated seal
- Improved cushion ring and special seal increase the absorbable kinetic energy
- Cushion needle avoid detachment
- Absorption kinetic energy is increased by using special packing

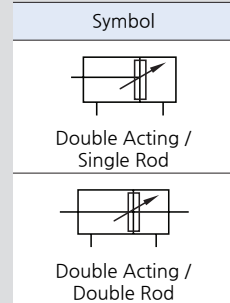

## How to Order

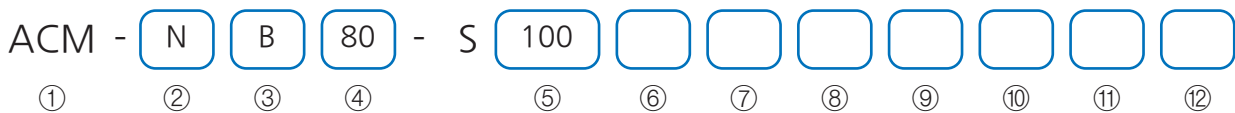

### ① Series

ACM	Double acting single rod medium cylinder
ACMW	Double acting double rod medium cylinder

### ② Lubrication

N	Not required(Standard)
L	Low hydraulic pressure (≤9.9kgf/cm <sup>2</sup> )
G	Low hydraulic pressure (≤24.5kgf/cm <sup>2</sup> )
Q	Low friction type

### ③ Mounting style

B	Standard	CB	Double clevis
LB	Foot	TC	Center trunnion
FA	Rod side flange	TA	Rod side trunnion
FB	Head side flange	TB	Head side trunnion
CA	Single clevis		

### ④ Tube size

40	50	63	80	100
Ø40	Ø50	Ø63	Ø80	Ø100

### ⑤ Cylinder stroke

Bore size	Standard stroke	Max. stroke
Ø40	25, 50, 75, 100, 125, 150, 175, 200, 250, 300, 350, 400, 450, 500, 550, 600, 650, 700, 750, 800, 850, 900, 950, 1000	2950
Ø50		
Ø63		
Ø80		
Ø80		
Ø100		

※ Other intermediate strokes is available upon request.  
 ※ Refer to page [1]-133, for specifications about custom-made rod ends.

### ⑥ Belows

	Material	Max. Temperature
Nil	Without bellows	
J	Nylon Tarpaulin	60°C
K	Neoprene Cloth	110°C

### ⑦ Rod end attachment

Nil	Rod end nut 1pc (Standard)
I	Single knuckle joint
Y	Double knuckle joint

### ⑧ Mounting bracket

Nil	None
KA2	Trunnion

### ⑨ Auto switch

Reed A/S	Model	Solid state A/S	Model
A54	D-A54K	F59	D-F59K
A56	D-A56K	F5P	D-F5PK
A64	D-A64K	J59	D-J59K
A90(V)	D-A90(V)K	J51	D-J51K
A93(V)	D-A93(V)K	F9N	D-F9N(V)K
A96(V)	D-A96(V)K	F9P	D-F9P(V)K
		F9B	D-F9B(V)K

※ Only for auto switch attached type.  
 ※ Refer to Auto Switch Catalogue for more information.

### ⑩ Number of auto switches

Nil	2 pcs
1	1 pc
N	N pcs (N: 3, 4, 5...)

※ Only for auto switch attached type.

### ⑪ Special order

Nil	None
TS	Multi-step stroke cylinder(Single rod)
TW	Multi-step stroke cylinder (Double rod)
TD	Tandem cylinder
ASJ	Stroke adjustable type (in forward direction within 25mm)
BSJ	Stroke adjustable type (in forward direction within 50mm)
S	Single acting spring return
T	Single acting spring extend
SV	Heat resistant cylinder (150°C)
SS	Stainless steel piston rod

### ⑫ Low friction direction

R	Side at pressure when pressurized on rod side
H	Side at pressure when pressurized on head size

※ Only for low friction type.

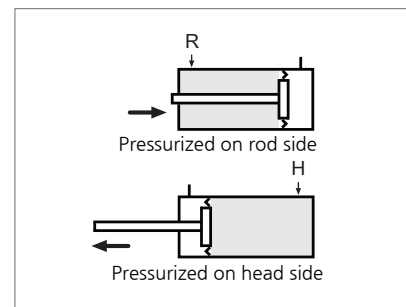

## Specifications

Type	Non-lubricated		Low hydraulic pressure
	Single rod	Double rod	
Fluid	Air		Hydraulic fluid
Proof pressure	14.7kgf/cm <sup>2</sup> (1.5MPa)		
Max. operating pressure	9.9kgf/cm <sup>2</sup> (1.0MPa)		Low pressure L type: 9.9kgf/cm <sup>2</sup> (1.0MPa) Low pressure G type: 24.5kgf/cm <sup>2</sup> (2.5MPa)
Min. operating pressure	0.5kgf/cm <sup>2</sup> (0.05MPa)		1.0kgf/cm <sup>2</sup> (0.1MPa)
Ambient & fluid temperature	5 ~ 60°C		
Operating piston speed	50 ~ 500mm/sec		0.5 ~ 300mm/sec
Cushion	Both side air cushion		None
Tolerance of thread	KS class 2		
Tolerance of stroke	~250 <sup>ST</sup> : $\begin{matrix} +1.0 \\ 0 \end{matrix}$	~1000 <sup>ST</sup> : $\begin{matrix} +1.4 \\ 0 \end{matrix}$	~1500 <sup>ST</sup> : $\begin{matrix} +1.8 \\ 0 \end{matrix}$

## Accessory

Mounting style		Standard	Foot	Rod Side Flange	Head Side Flange	Single clevis	Double clevis	Trunnion
Standard	Rod end nut	●	●	●	●	●	●	●
	Clevis pin	-	-	-	-	-	●	-
Option	Single knuckle joint	●	●	●	●	●	●	●
	Double knuckle joint	●	●	●	●	●	●	●
	Bellows	●	●	●	●	●	●	●

※ For double clevis type & double knuckle joint type, pin and snap ring are included.

## Mounting Style

Bore size	Ø40	Ø50	Ø63	Ø80	Ø100
Foot	LB40	LB50	LB63	LB80	LB100
Flange	FA/FB40	FA/FB50	FA/FB63	FA/FB80	FA/FB100
Single clevis (With pin)	CA40	CA50	CA63	CA80	CA100
Double clevis (With pin)	CB40	CB50	CB63	CB80	CB100

※ Foot mounting basically 2 pcs/set.

## Rod End Attachment

Bore size Rod end attachment	Ø40	Ø50, Ø63	Ø80	Ø100
Single knuckle joint	I40	I50/63	I80	I100
Double knuckle joint	Y40	Y50/63	Y80	Y100

## Mass

Unit: kg

Bore size (mm)		Double acting single rod					Double acting double rod				
		Ø40	Ø50	Ø63	Ø80	Ø100	Ø40	Ø50	Ø63	Ø80	Ø100
Basis mass	Standard	0.79	1.13	1.41	2.64	3.54	0.90	1.28	1.58	3.00	3.96
	Foot	0.96	1.34	1.71	3.33	4.36	1.08	1.49	1.88	3.70	4.78
	Flange	0.92	1.30	1.68	3.15	4.22	1.04	1.45	1.86	3.52	4.64
	Single clevis	1.05	1.51	2.15	3.91	5.52	-	-	-	-	-
	Double clevis (with pin)	1.08	1.60	2.10	4.02	5.69	-	-	-	-	-
	Trunnion	1.15	1.61	2.21	4.19	7.21	1.26	1.76	2.38	4.55	7.63
Additional mass per each 50mm of stroke		0.17	0.21	0.27	0.46	0.60	0.25	0.28	0.35	0.66	0.91
Accessory	Single knuckle joint	0.17	0.23	0.23	0.49	0.68	-	-	-	-	-
	Double knuckle joint (with pin)	0.22	0.30	0.30	0.64	0.92	-	-	-	-	-
	Trunnion type support bracket	0.54	0.54	0.88	2.04	2.04	-	-	-	-	-
	Rod nut	0.02	0.03	0.03	0.05	0.12	-	-	-	-	-

Calculation:

Ex) ACM-LB40-S100  
Basis mass: 0.962(Foot Ø40) / Addtional mass: 0.168/50 / Stroke: 100mm  
 $0.962 + 0.168/50 \times 100 = 1.298\text{kg}$

Structure

Standard (Non Lubricated type)  
ACM N-B

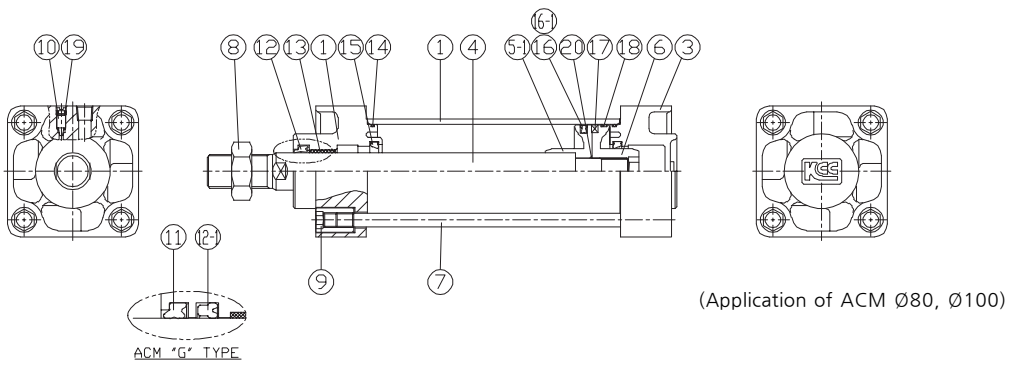
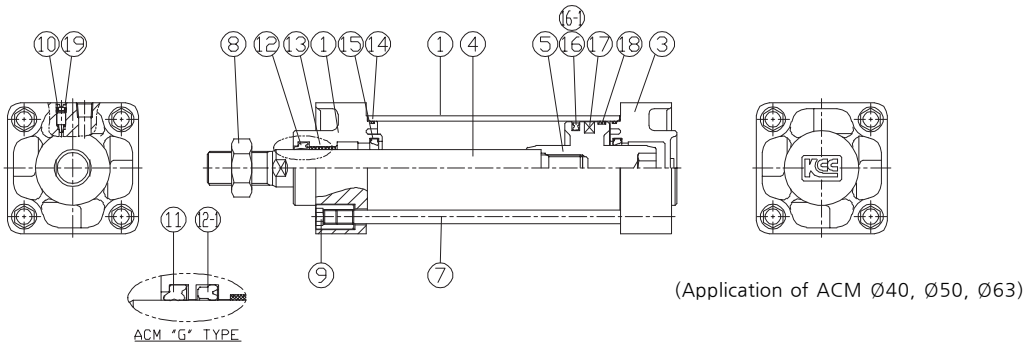

\* New version cover has a longer cushion length. It is a patented model.

No.	Parts	Material	Remark
1	Tube	A6063-T5	
2	Rod cover	AL DC12	
3	Head cover	AL DC12	
4	Rod	SM45C	
5	Piston	ALDC12	
5-1	Piston(A)	AC4C	Application of ACM Ø80, Ø100
6	Magnet holder	AC4C	Application of ACM Ø80, Ø100
7	Tie rod	SM20C	
8	Rod end nut	SS400	
9	Tie rod nut	SM20C	
10	Cushon needle	ST303	

No.	Parts	Material	Bore size (mm)					Remark
			40	50	63	80	100	
11	Dust seal	N.B.R	SDR-16	SDR-20	SDR-20	SDR-25	SDR-30	High Low Hydraulic Type
12	Rod packing	N.B.R	DRP-16	DRP-20	DRP-20	DRP-25	DRP-30	
12-1	Rod packing (G)	N.B.R	SKY-16	SKY-20	SKY-20	SKY-25	SKY-30	High Low Hydraulic Type
13	DU bush	SPCC	DUB1612	DUB2015	DUB2015	DUB2015	DUB3020	
14	Tube O-ring	N.B.R	Ø38X1.5	Ø48X1.5	S60	S77	S97	
15	Cushion packing	URETHANE	KP-20	KP-24	KP-24	KP-30	KP-35	
16	Piston packing	N.B.R	OPA-40	OPA-50	OPA-63	OPA-80	OPA100	
16-1	Piston packing (G)	N.B.R	HSD-40	HSD-50	HSD-63	HSD-80	HSD-100	High Low Hydraulic Type
17	Magnet		Ø40	Ø50	Ø63	Ø80	Ø100	
18	Wearing	POLYKETON	SWB40	SWB50	SWB63	SWB80	SWB100	
19	Needle O-ring	N.B.R	S8	S8	S8	S8	S8	
20	Rod packing	N.B.R	-	-	-	S16	S20	

Dimensions-Standard (B)

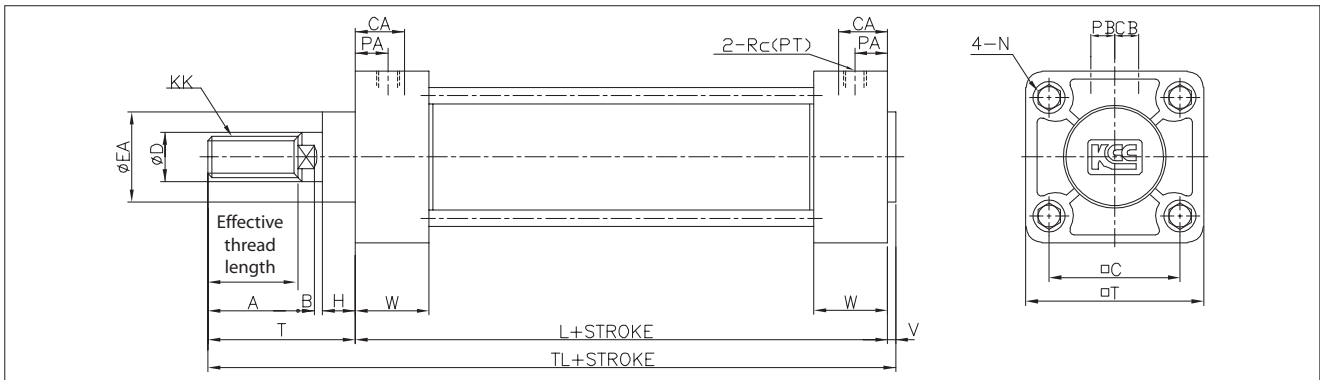

Unit : mm

Bore size	Effective thread length	A	B	□C	CA	CB	ØD	ØEA	H	KK	L	N	PA
Ø40	27	30	6	44	17.5	8.5	16	32	12	M14XP1.5	84	M8XP1.25	15.4
Ø50	32	35	7	52	19.5	11	20	40	12	M18XP1.5	90	M8XP1.25	14
Ø63	32	35	7	64	23	11	20	40	12	M18XP1.5	98	M8XP1.25	15
Ø80	37	40	11	78	24	14	25	52	17	M22XP1.5	116	M12XP1.75	17.5
Ø100	37	40	11	92	26.5	14.5	30	52	17	M26XP1.5	126	M12XP1.75	20

Bore size	PB	Rc(PT)	T	□T	TL	V	W
Ø40	6.5	1/4	51	60	138	3	26
Ø50	8	3/8	58	70	151	3	27
Ø63	8	3/8	58	83	159	3	29
Ø80	13	1/2	71	102	194	7	33.5
Ø100	13	1/2	72	116	205	7	36

Dimensions-Foot (LB)

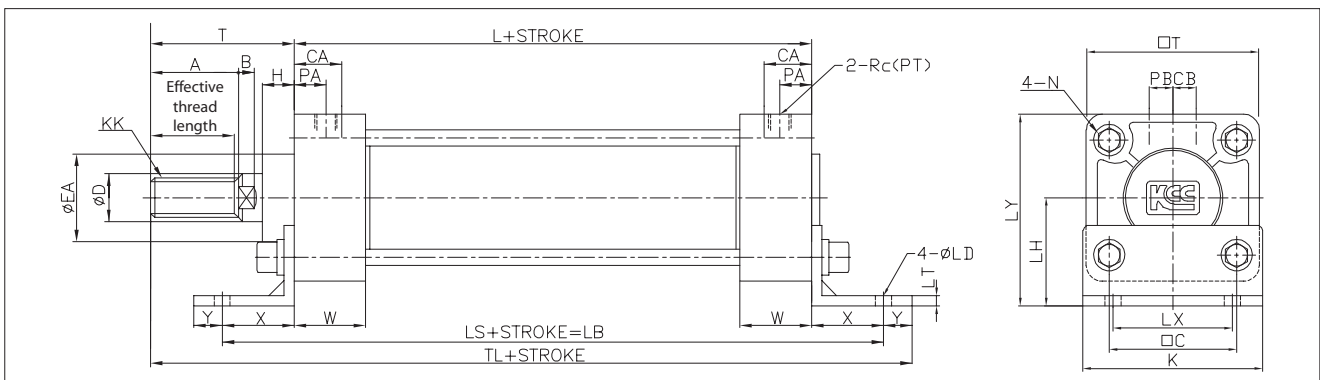

Unit : mm

Bore size	Effective thread length	A	B	□C	CA	CB	ØD	ØEA	H	K	KK	L	ØLD	LH
Ø40	27	30	6	44	17.5	8.5	16	32	12	60	M14XP1.5	84	9	40
Ø50	32	35	7	52	19.5	11	20	40	12	70	M18XP1.5	90	9	45
Ø63	32	35	7	64	23	11	20	40	12	85	M18XP1.5	98	11.5	50
Ø80	37	40	11	78	24	14	25	52	17	102	M22XP1.5	116	13.5	65
Ø100	37	40	11	92	26.5	14.5	30	52	17	116	M26XP1.5	126	13.5	75

Bore size	LS	LT	LX	LY	N	PA	PB	Rc(PT)	T	□T	TL	W	X	Y
Ø40	138	3	42	70	M8XP1.25	15.4	6.5	1/4	51	60	175	26	27	(13)
Ø50	144	3	50	80	M8XP1.25	14	8	3/8	58	70	188	27	27	(13)
Ø63	166	3	59	91.5	M8XP1.25	15	8	3/8	58	83	206	29	34	(16)
Ø80	204	5	76	116	M12XP1.75	17.5	13	1/2	71	102	247	33.5	44	(16)
Ø100	212	5	92	133	M12XP1.75	20	13	1/2	72	116	258	36	43	(17)

Dimensions-Rod Side Flange (FA)

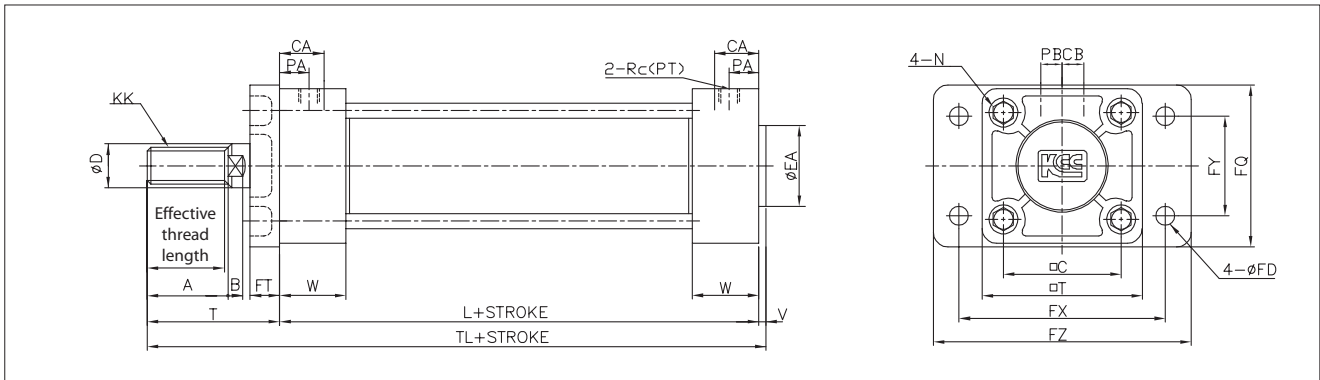

Unit : mm

Bore size	Effective thread length	A	B	$\square C$	CA	CB	$\phi D$	$\phi EA$	FD	FQ	FT	FX	FY	FZ
$\phi 40$	27	30	6	44	17.5	8.5	16	32	9	65	12	80	42	100
$\phi 50$	32	35	7	52	19.5	11	20	40	9	75	12	90	50	110
$\phi 63$	32	35	7	64	23	11	20	40	11.5	90	15	105	59	130
$\phi 80$	37	40	11	78	24	14	25	52	13.5	110	18	130	76	160
$\phi 100$	37	40	11	92	26.5	14.5	30	52	13.5	126	18	150	92	180

Bore size	KK	L	N	PA	PB	Rc(PT)	T	$\square T$	TL	V	W
$\phi 40$	M14XP1.5	84	M8XP1.25	15.4	6.5	1/4	51	60	138	3	26
$\phi 50$	M18XP1.5	90	M8XP1.25	14	8	3/8	58	70	151	3	27
$\phi 63$	M18XP1.5	98	M8XP1.25	15	8	3/8	58	83	159	3	29
$\phi 80$	M22XP1.5	116	M12XP1.75	17.5	13	1/2	71	102	194	7	33.5
$\phi 100$	M26XP1.5	126	M12XP1.75	20	13	1/2	72	116	205	7	36

Dimensions-Head Side Flange (FB)

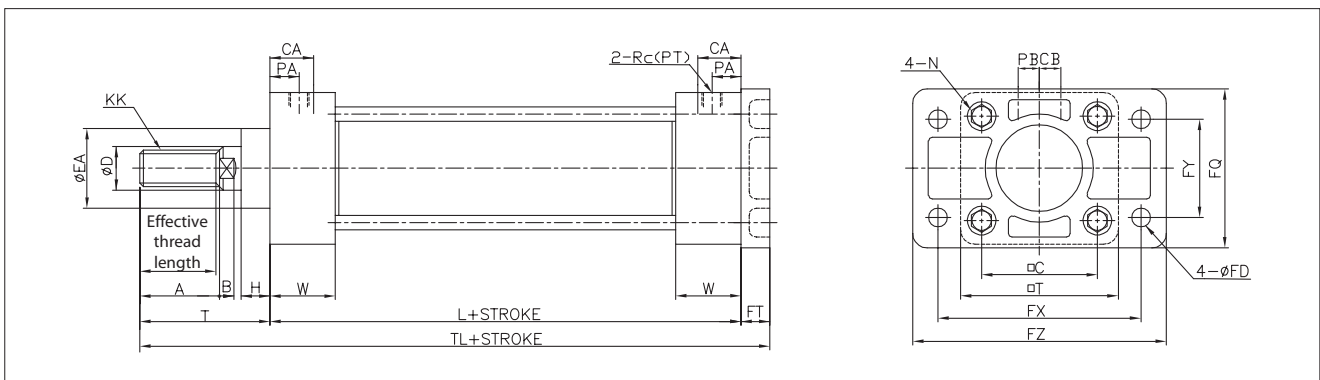

Unit : mm

Bore size	Effective thread length	A	B	$\square C$	CA	CB	$\phi D$	$\phi EA$	$\phi FD$	FQ	FT	FX	FY	FZ	H
$\phi 40$	27	30	6	44	17.5	8.5	16	32	9	65	12	80	42	100	12
$\phi 50$	32	35	7	52	19.5	11	20	40	9	75	12	90	50	110	12
$\phi 63$	32	35	7	64	23	11	20	40	11.5	90	15	105	59	130	12
$\phi 80$	37	40	11	78	24	14	25	52	13.5	110	18	130	76	160	17
$\phi 100$	37	40	11	92	26.5	14.5	30	52	13.5	126	18	150	92	180	17

Bore size	KK	L	N	PA	PB	Rc(PT)	T	$\square T$	TL	W
$\phi 40$	M14XP1.5	84	M8XP1.25	15.4	6.5	1/4	51	60	147	26
$\phi 50$	M18XP1.5	90	M8XP1.25	14	8	3/8	58	70	160	27.5
$\phi 63$	M18XP1.5	98	M8XP1.25	15	8	3/8	58	83	171	29.5
$\phi 80$	M22XP1.5	116	M12XP1.75	17.5	13	1/2	71	102	205	34
$\phi 100$	M26XP1.5	126	M12XP1.75	20	13	1/2	72	116	216	36.5

Dimensions-Single Clevis (CA)

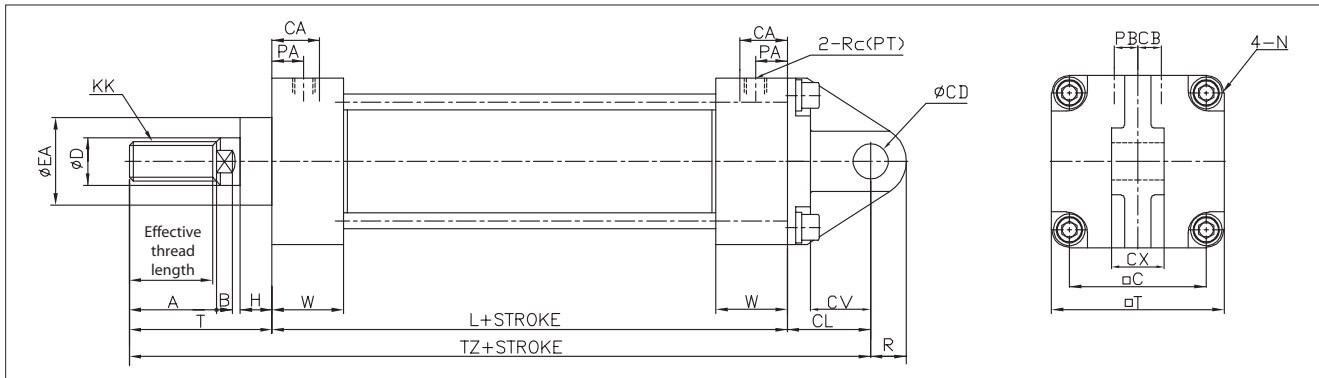

Unit : mm

Bore size	Effective thread length	A	B	□C	CA	CB	ØCD	CL	CV	CX	ØD	ØEA	H
Ø40	27	30	6	44	17.5	8.5	10 <sup>+0.070</sup> / <sub>+0.0</sub>	30	18	15.0 <sup>-0.1</sup> / <sub>-0.3</sub>	16	32	12
Ø50	32	35	7	52	19.5	11	12 <sup>+0.15</sup> / <sub>+0.10</sub>	35	23	18.0 <sup>-0.1</sup> / <sub>-0.3</sub>	20	40	12
Ø63	32	35	7	64	23	11	16 <sup>+0.15</sup> / <sub>+0.10</sub>	40	27	25.0 <sup>-0.1</sup> / <sub>-0.3</sub>	20	40	12
Ø80	37	40	11	78	24	14	20 <sup>+0.15</sup> / <sub>+0.10</sub>	48	34	31.5 <sup>-0.1</sup> / <sub>-0.3</sub>	25	52	17
Ø100	37	40	11	92	26.5	14.5	25 <sup>+0.15</sup> / <sub>+0.10</sub>	58	43	35.5 <sup>-0.1</sup> / <sub>-0.3</sub>	30	52	17

Bore size	KK	L	N	PA	PB	R	Rc(PT)	T	□T	TZ	W
Ø40	M14XP1.5	84	M8XP1.25	15.4	6.5	(10)	1/4	51	60	165	26
Ø50	M18XP1.5	90	M8XP1.25	14	8	(12)	3/8	58	70	183	27
Ø63	M18XP1.5	98	M8XP1.25	15	8	(16)	3/8	58	83	196	29
Ø80	M22XP1.5	116	M12XP1.75	17.5	13	(20)	1/2	71	102	235	33.5
Ø100	M26XP1.5	126	M12XP1.75	20	13	(25)	1/2	72	116	256	36

Dimensions-Double Clevis (CB)

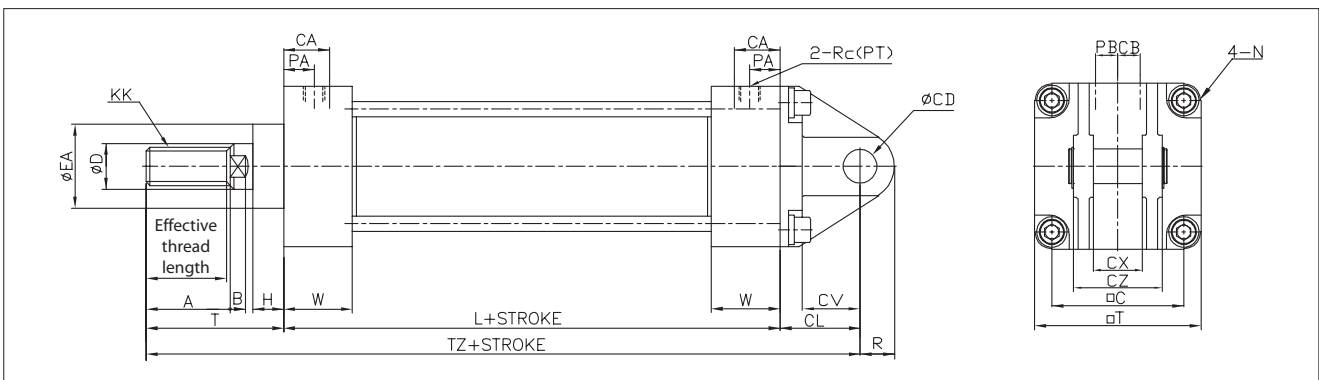

Unit : mm

Bore size	Effective thread length	A	B	□C	CA	CB	ØCD	CL	CV	CX	CZ	ØD	ØEA
Ø40	27	30	6	44	17.5	8.5	10 <sup>+0.070</sup> / <sub>+0.0</sub>	30	18	15.0 <sup>+0.3</sup> / <sub>+0.1</sub>	29.5	16	32
Ø50	32	35	7	52	19.5	11	12 <sup>+0.15</sup> / <sub>+0.10</sub>	35	23	18.0 <sup>+0.3</sup> / <sub>+0.1</sub>	38	20	40
Ø63	32	35	7	64	23	11	16 <sup>+0.15</sup> / <sub>+0.10</sub>	40	27	25.0 <sup>+0.3</sup> / <sub>+0.1</sub>	49	20	40
Ø80	37	40	11	78	24	14	20 <sup>+0.15</sup> / <sub>+0.10</sub>	48	34	31.5 <sup>+0.3</sup> / <sub>+0.1</sub>	61	25	52
Ø100	37	40	11	92	26.5	14.5	25 <sup>+0.15</sup> / <sub>+0.10</sub>	58	43	35.5 <sup>+0.3</sup> / <sub>+0.1</sub>	64	30	52

Bore size	H	KK	L	N	PA	PB	R	Rc(PT)	T	□T	TZ	W
Ø40	12	M14XP1.5	84	M8XP1.25	15.4	6.5	(10)	1/4	51	60	165	26
Ø50	12	M18XP1.5	90	M8XP1.25	14	8	(12)	3/8	58	70	183	27
Ø63	12	M18XP1.5	98	M8XP1.25	15	8	(16)	3/8	58	83	196	29
Ø80	17	M22XP1.5	116	M12XP1.75	17.5	13	(20)	1/2	71	102	235	33.5
Ø100	17	M26XP1.5	126	M12XP1.75	20	13	(25)	1/2	72	116	256	36

Dimensions-Center Trunnion (TC), Rod Side Trunnion (TA), Head Side Trunnion (TB)

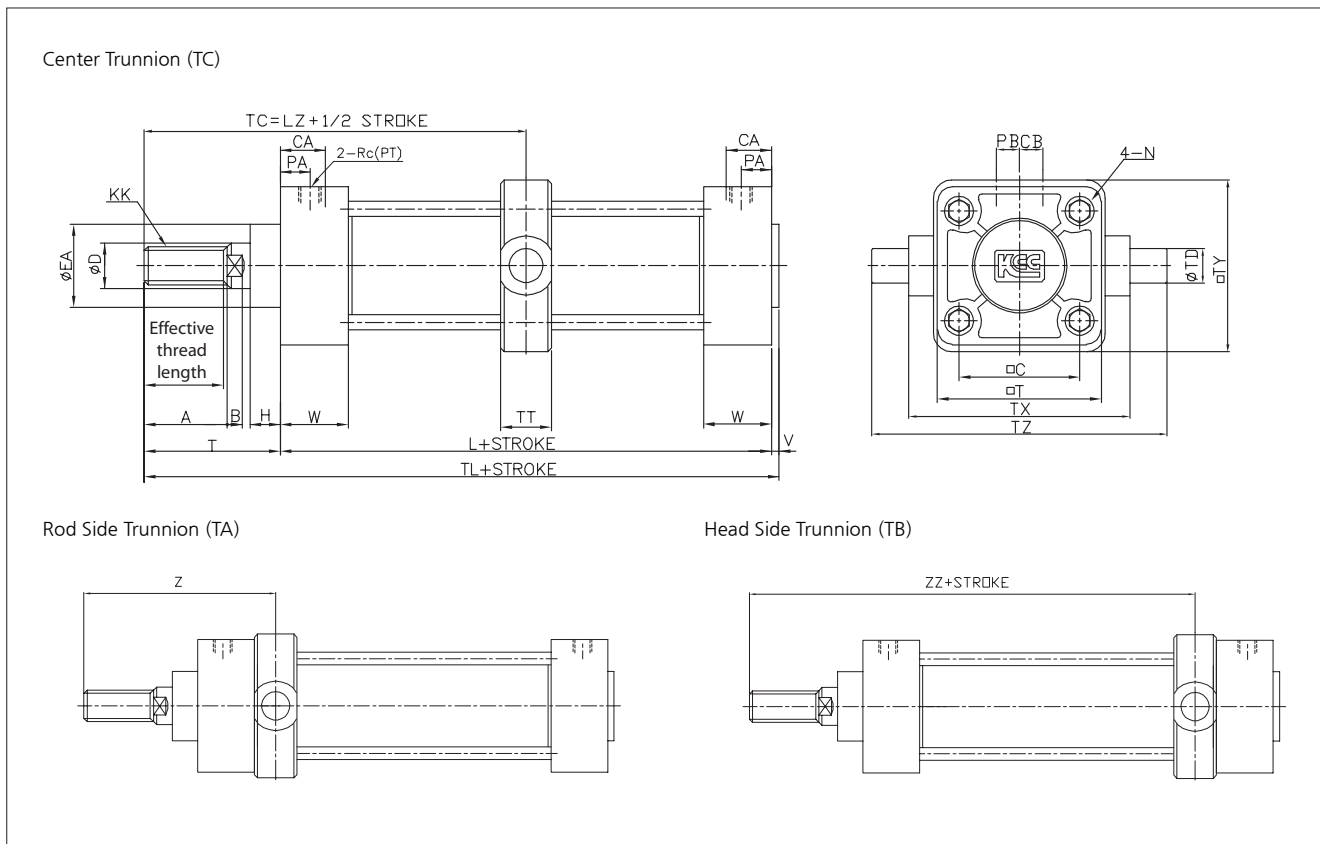

Unit : mm

Bore size	Effective thread length	A	B	□C	CA	CB	∅D	∅EA	H	KK	L	LZ	N
∅40	27	30	6	44	17.5	8.5	16	32	12	M14XP1.5	84	93	M8XP1.25
∅50	32	35	7	52	19.5	11	20	40	12	M18XP1.5	90	103	M8XP1.25
∅63	32	35	7	64	23	11	20	40	12	M18XP1.5	98	107	M8XP1.25
∅80	37	40	11	78	24	14	25	52	17	M22XP1.5	116	129	M12XP1.75
∅100	37	40	11	92	26.5	14.5	30	52	17	M26XP1.5	126	135	M12XP1.75

Bore size	PA	PB	Rc(PT)	T	□T	∅TD	TL	TT	TX	TY	TZ	V	W	Z	ZZ
∅40	15.4	6.5	1/4	51	60	15 <sup>-0.05</sup> <sub>-0.10</sub>	138	22	85	62	117	3	26	88	98
∅50	14	8	3/8	58	70	15 <sup>-0.05</sup> <sub>-0.10</sub>	151	22	95	74	127	3	27	96.5	109.5
∅63	15	8	3/8	58	83	18 <sup>-0.05</sup> <sub>-0.10</sub>	159	28	110	90	148	3	29	101.5	112.5
∅80	17.5	13	1/2	71	102	25 <sup>-0.05</sup> <sub>-0.10</sub>	194	34	140	110	192	7	33.5	122	136
∅100	20	13	1/2	72	116	25 <sup>-0.05</sup> <sub>-0.10</sub>	205	40	162	130	214	7	36	128.5	141.5

Dimensions-Trunnion Bracket (KA2)

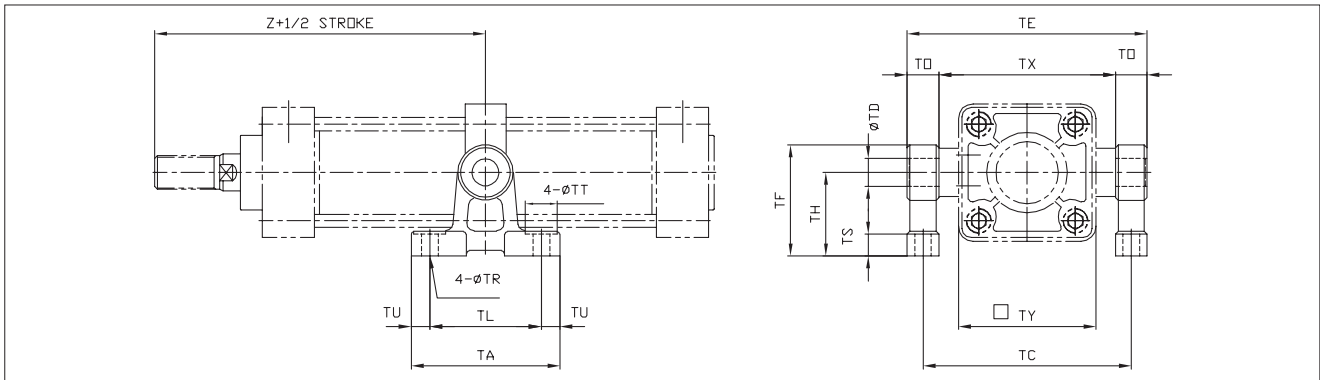

Unit : mm

Part No.	Bore size	TA	TC	TDH10 (Hole)	TE	TF	TH	TL	TO	TR	TS
KA2-40/50	Ø40	80	102	15 <sup>+0.070</sup> <sub>0</sub>	119	60	45	60	17	9	12
	Ø50	80	112	15 <sup>+0.070</sup> <sub>0</sub>	129	60	45	60	17	9	12
KA2-63	Ø63	100	130	18 <sup>+0.070</sup> <sub>0</sub>	150	73	55	70	20	11	14
KA2-80/100	Ø80	120	166	25 <sup>+0.084</sup> <sub>0</sub>	192	100	75	90	26	13.5	17
	Ø100	120	188	25 <sup>+0.084</sup> <sub>0</sub>	214	100	75	90	26	13.5	17

Part No.	TU	TX	TY	Z
KA2-40/50	10	85	62	93
	10	95	74	103
KA2-63	15	110	90	107
KA2-80/100	15	140	110	129
	15	162	130	135

Dimensions-Accessory

Single Knuckle Joint

Material: Free-cutting steel

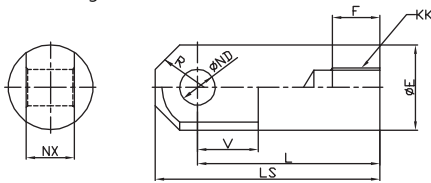

Unit : mm

Part No.	Bore size	ØE	F	KK	L	LS	ØND	NX	R	V
I40	Ø40	24	22	M14X1.5	55	69	12 <sup>+0.070</sup> <sub>0</sub>	16 <sup>-0.1</sup> <sub>-0.3</sub>	15.5	20
I50	Ø50, 63	28	27	M18X1.5	60	74	12 <sup>+0.070</sup> <sub>0</sub>	16 <sup>-0.1</sup> <sub>-0.3</sub>	15.5	20
I80	Ø80	36	37	M22X1.5	71	91	18 <sup>+0.070</sup> <sub>0</sub>	28 <sup>-0.1</sup> <sub>-0.3</sub>	22.5	26
I100	Ø100	40	37	M26X1.5	83	105	20 <sup>+0.084</sup> <sub>0</sub>	30 <sup>-0.1</sup> <sub>-0.3</sub>	24.5	28

Double Knuckle Joint

Material: FC 40

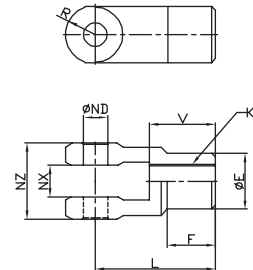

Unit : mm

Part No.	Bore size	ØE	F	KK	L	ØND <sup>H10</sup>	NX	NZ	R	V
Y40	Ø40	24	22	M14X1.5	55	12 <sup>+0.070</sup> <sub>0</sub>	16 <sup>+0.3</sup> <sub>+0.1</sub>	38	13	30
Y50	Ø50, 63	28	24	M18X1.5	60	12 <sup>+0.070</sup> <sub>0</sub>	16 <sup>+0.3</sup> <sub>+0.1</sub>	38	15	30
Y80	Ø80	36	33	M22X1.5	71	18 <sup>+0.070</sup> <sub>0</sub>	28 <sup>+0.3</sup> <sub>+0.1</sub>	55	19	43
Y100	Ø100	40	34	M26X1.5	83	20 <sup>+0.84</sup> <sub>0</sub>	30 <sup>+0.3</sup> <sub>+0.1</sub>	61	21	45

Rod End Nut

Material: Rolled steel

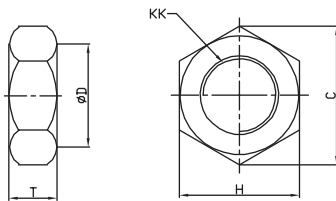

Unit : mm

Part No.	Bore size	C	ØD	H	KK	T
RN-04	Ø40	25.4	21	22	M14X1.5	8
RN-05	Ø50, 63	31.2	26	27	M18X1.5	11
RN-08	Ø80	37.0	31	32	M22X1.5	13
RN-10	Ø100	47.3	39	41	M26X1.5	16

Clevis Pin

Material: Carbon steel

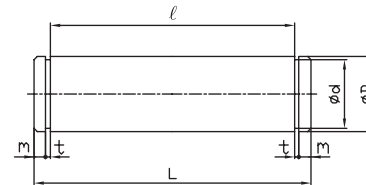

Unit : mm

Part No.	Bore size	ØDd9	Ød	L	ℓ	m	t
CP-04	Ø40	10 <sup>-0.040</sup> <sub>-0.076</sub>	Ø9	35.8	29.8	1.85	1.15
CP-05	Ø50	12 <sup>-0.050</sup> <sub>-0.093</sub>	Ø11	44.5	38.2	2	1.15
CP-06	Ø63	16 <sup>-0.050</sup> <sub>-0.093</sub>	Ø14.5	55.3	49.2	1.9	1.15
CP-08	Ø80	20 <sup>-0.065</sup> <sub>-0.117</sub>	Ø18.5	68.2	61.2	2.15	1.35
CP-10	Ø100	25 <sup>-0.065</sup> <sub>-0.117</sub>	Ø23	71.2	64.2	2.15	1.35

Knuckle Joint Pin

Material: Carbon steel

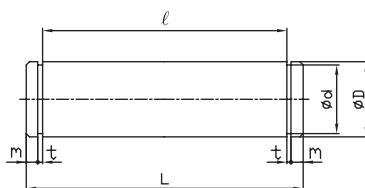

Unit : mm

Part No.	Bore size	ØDd9	Ød	L	ℓ	m	t
JP-04	Ø40, 50, 63	12 <sup>-0.050</sup> <sub>-0.093</sub>	Ø11	44.5	38.2	2	1.15
JP-08	Ø80	18 <sup>-0.050</sup> <sub>-0.093</sub>	Ø16.5	62.5	55.2	2.3	1.35
JP-10	Ø100	20 <sup>-0.065</sup> <sub>-0.117</sub>	Ø18.5	68.2	61.2	2.15	1.35

**Dimensions-Bellows Attached Type (J, K)**

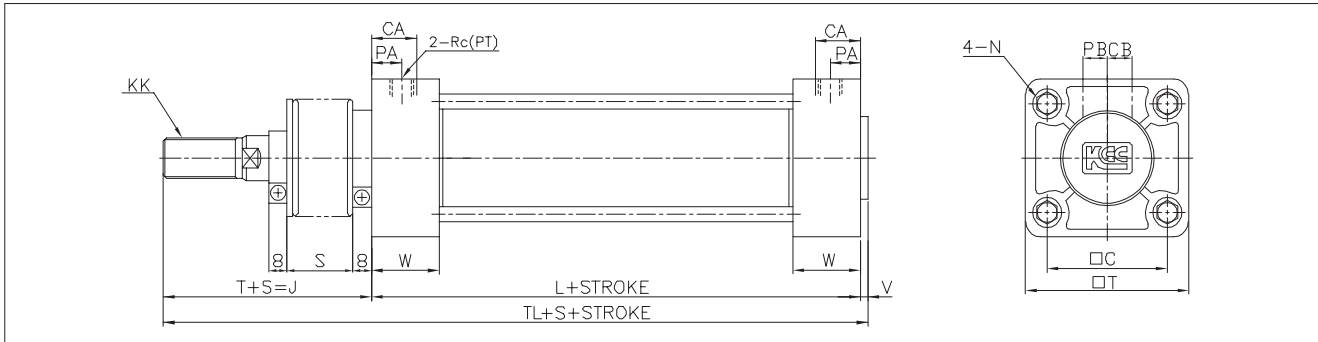

Unit : mm

Bore size	□C	CA	CB	ØEB	KK	L	N	PA	PB	Rc(PT)	Rc(PT)	S
Ø40	44	17.5	8.5	43	M14XP1.5	84	M8XP1.25	15.4	6.5	1/4	1/4	1/4 stroke
Ø50	52	19.5	11	52	M18XP1.5	90	M8XP1.25	14	8	3/8	3/8	1/4 stroke
Ø63	64	23	11	52	M18XP1.5	98	M8XP1.25	15	8	3/8	3/8	1/4 stroke
Ø80	78	24	14	65	M22XP1.5	116	M12XP1.75	17.5	13	1/2	1/2	1/4 stroke
Ø100	92	26.5	14.5	65	M26XP1.5	126	M12XP1.75	20	13	1/2	1/2	1/4 stroke

Bore size	T	□T	TL	V	W
Ø40	59	60	146	3	26
Ø50	66	70	159	3	27
Ø63	66	83	167	3	29
Ø80	80	102	203	7	33.5
Ø100	81	116	214	7	36

Type	J	K
Material	Nylon Tarpaulin	Neoprene Cloth
Heat resistant	60°C	110°C

※ For dimensions not shown in these figures, refer to the ACM (Standard) type.  
 ※ SUS band is mounted at bellows at delivery.

**Dimensions-Double Rod (ACMW)**

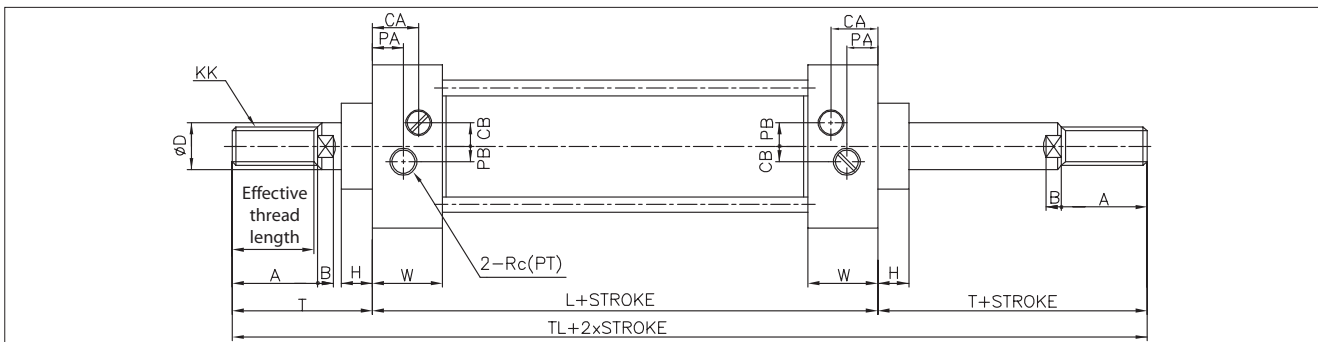

Unit : mm

Bore size	Effective thread length	A	B	CA	CB	ØD	H	KK	L	PA	PB	Rc(PT)
Ø40	27	30	6	17.5	8.5	16	12	M14XP1.5	84	12.5	6.5	1/4
Ø50	32	35	7	19.5	11	20	12	M18XP1.5	90	14	8	3/8
Ø63	32	35	7	23	11	20	12	M18XP1.5	98	15	9	3/8
Ø80	37	40	11	24	14	25	17	M22XP1.5	116	19	12	1/2
Ø100	37	40	11	26.5	14	30	17	M26XP1.5	126	20	12	1/2

Bore size	T	TL	W
Ø40	51	186	26.5
Ø50	58	206	27
Ø63	58	214	29
Ø80	71	258	33.5
Ø100	72	270	36

※ For dimensions not shown in these figures, refer to the ACM (Standard) type.

### Single Rod Multi-Step Stroke Cylinder (TS)

By integrating two cylinders in series enable back and forth stroke and two-steps control for a doubled output.

Ordering notation: A Stroke + Total Stroke

Ex) 150 + 200 (A Side = 150, B Side = 50)

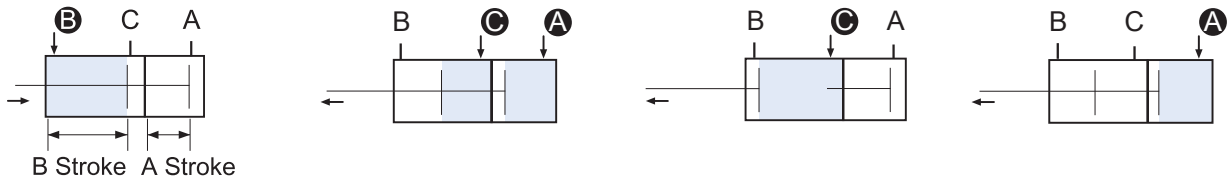

When B port is supplied with air pressure, A and B strokes reverse.

When both A and C ports are supplied with air pressure, forward output is doubled.

When C port is supplied with air pressure, rod and B Stroke move forward.

When A port is supplied with air pressure, rod and A Stroke move forward.

### Dimensions-Single Rod Multi-Step Stroke Cylinder (TS)

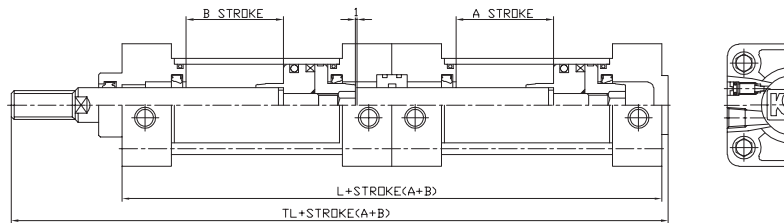

Unit : mm

Bore size	L	TL
Ø40	168	222
Ø50	180	241
Ø63	196	257
Ø80	232	310
Ø100	252	331

※ For dimensions not shown in these figures, refer to the ACM (Standard) type.

### Double Rod Multi-Step Stroke Cylinder (TW)

Head side assembly. By integrating two cylinders enable back and forth stroke and three steps control.

Ordering notation: A Stroke + B Stroke

Example) 150 + 200 (A Side = 150, B Side = 200)

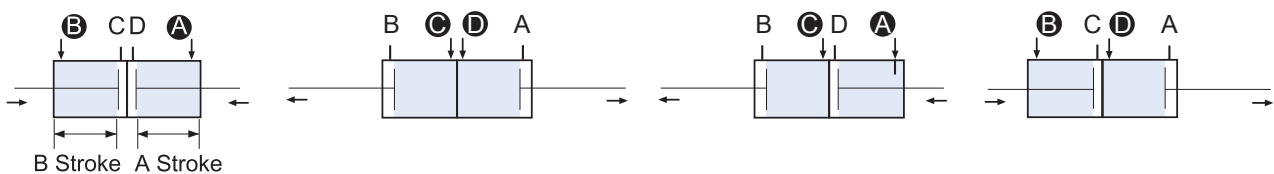

When A and B ports are supplied with air pressure, A and B strokes reverse.

When C and D ports are supplied with air pressure, A and B strokes move forward.

When A and C ports are supplied with air pressure, B stroke move forward.

When B and D ports are supplied with air pressure, A stroke move forward.

### Dimensions-Double Rod Multi-Step Stroke Cylinder (TW)

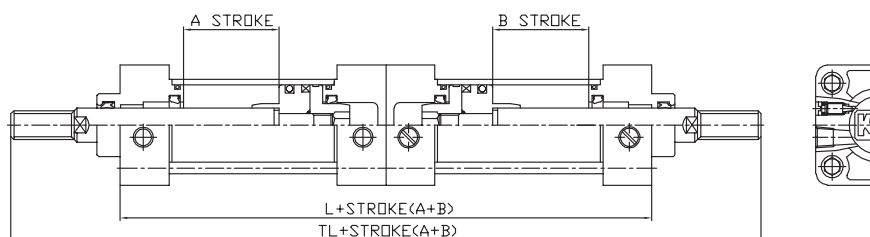

Unit : mm

Bore size	L	TL
Ø40	168	270
Ø50	180	296
Ø63	196	312
Ø80	232	374
Ø100	252	396

### Tandem Cylinder (TD)

Two cylinders connected in series for a doubled output.

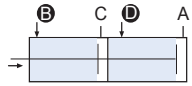

When A and B ports are supplied with air pressure, reverse operating output is doubled.

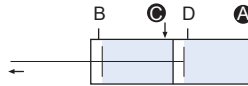

When A and C ports are supplied with air pressure, forward operating output is doubled.

### Dimensions-Tandem Cylinder (TD)

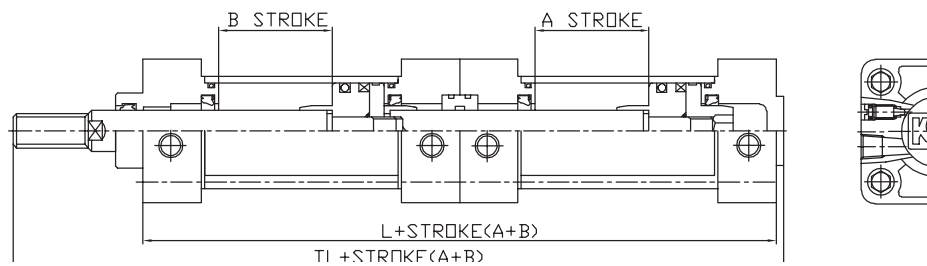

Unit : mm

Bore size	L	TL
Ø40	168	222
Ø50	180	241
Ø63	196	257
Ø80	232	310
Ø100	252	331

※ For dimensions not shown in these figures, refer to the ACM (Standard) type.

### Stroke Adjustable Cylinder (ASJ, BSJ)

To adjust the entire forward stroke from 0mm to 50mm an adjustment mechanism is attached to the head side.

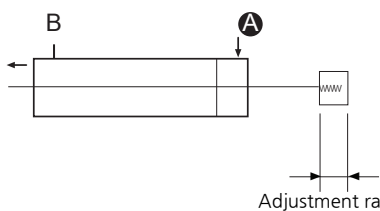

ASJ : 25mm adjustment  
BSJ : 50mm adjustment  
XSJ : Xmm adjustment (X is defined by user)

### Dimensions-Stroke Adjustable Type (ASJ, BSJ)

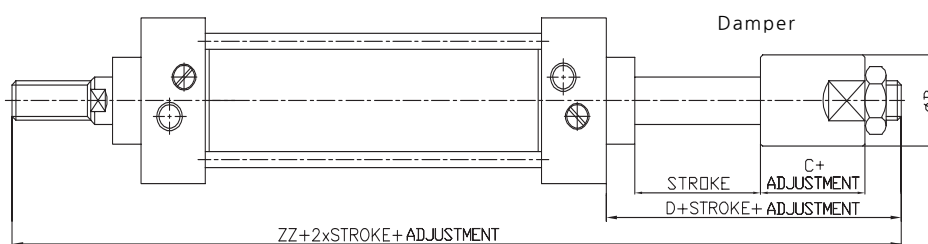

Unit : mm

Bore size	ØB	C	D	ZZ
Ø40	Ø32	22	46	181
Ø50	Ø42	28	58.5	206.5
Ø63		28	54	210
Ø80	Ø50	35	70	257
Ø100		35	60	270

※ For dimensions not shown in these figures, refer to the ACM (Standard) type.

### Low Friction Cylinder (Q)

Working at low pressure even when sliding resistance is low. Smooth operation is available even in low speed.

#### Specifications

Lubrication	No lubricated
Direction of low friction operation	Single direction (R-Air supply, H-Air supply)
Proof Pressure	10.5kgf/cm <sup>2</sup> (1.05MPa)
Max. operating pressure	9.9kgf/cm <sup>2</sup> (0.99MPa)
Min. operating pressure	0.02kgf/cm <sup>2</sup> (0.002MPa)
Cushion	None
Inner leakage	Below 0.5 l/min (ANR)
Ambient temperature	-10~60°C

#### Applications

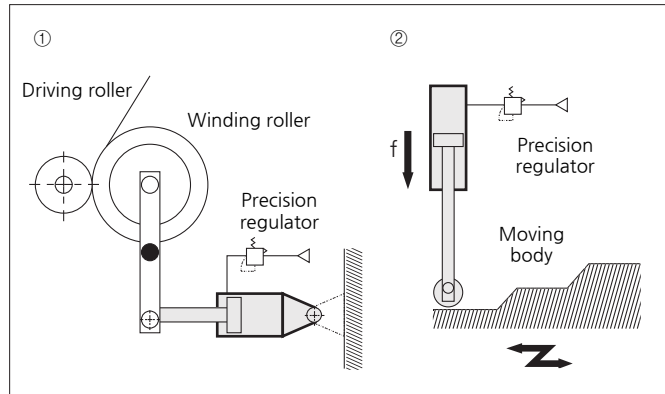

#### Sliding Resistance of Low Friction Side

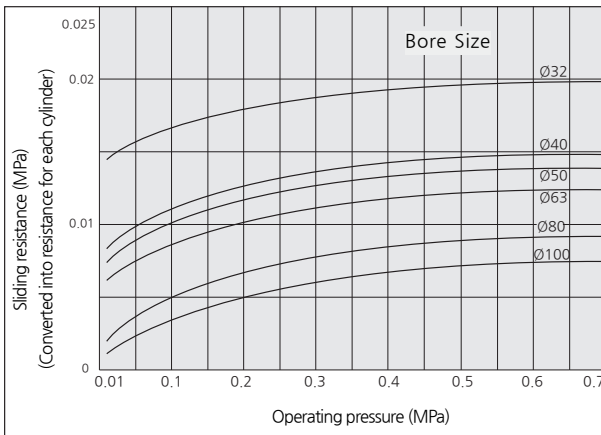

1. When used as a balancer etc., follow the example of the application mentioned earlier applying pressure at one port while leaving the other port open to atmosphere.

With pressure at rod cover port

..... Low friction side R (Example of application ①)

With pressure at head cover port

..... Low friction side H (Example of application ②)

2. If pressurized at the same time in both directions port, follow the above ①.

When the direction of the rod cover port is relatively high pressure:

..... Low friction side R

When a headcover port is a relatively high pressure:

..... Low friction side H

※ Use low friction cylinders in combination with precision regulator.

#### Dimensions-Low Friction Type (ACM Q)

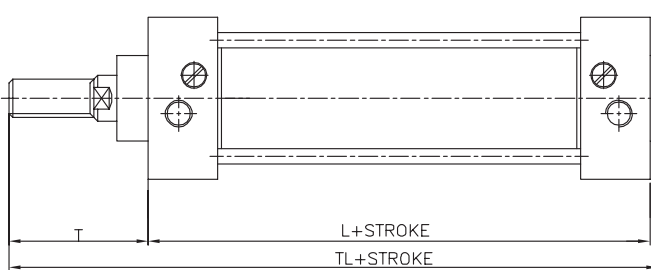

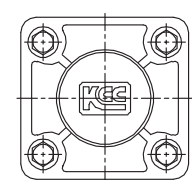

Unit : mm			
Bore size	L	T	TL
Ø40	94	51	148
Ø50	100	58	161
Ø63	108	58	169
Ø80	126	71	204
Ø100	136	72	215

#### Head Resistant Cylinder (SV)

Heat resistant cylinder can be used at a high ambient temperature up to 150°C by equipped with heat-resistant seal.

#### Specifications

Type	Lubricated
Bore size	Ø40, Ø50, Ø63, Ø80, Ø100
Temperature	-20~150°C
Packing Material	VITON

#### Stainless Steel Piston Rod (SS)

Stainless steel cylinder rod is selected to prevent the end of rod from corrosion when it is in contact with water during operation.

#### Specifications

Type	Lubricated, No lubricated
Bore size	Ø40, Ø50, Ø63, Ø80, Ø100
Rod Material	SUS304

# ACMK series

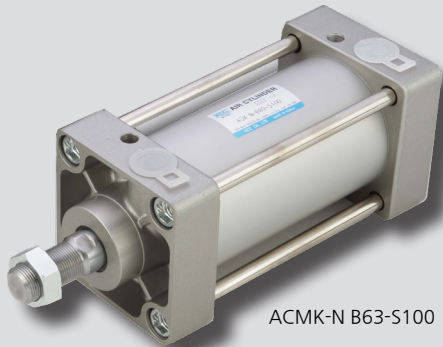

ACMK-N B63-S100

※ Dimensions are the same as those of the ACM series

## Feature

- With built-in magnet (Standard)
- With non-lubricated seal
- Improved cushion ring and special seal increase the absorbable kinetic energy
- The Cushion needle avoids detachment

## How to order



### ① Series

ACMK	Rod rotation prevention single rod medium cylinder
ACMWK	Rod rotation prevention double rod medium cylinder

### ② Mounting style

B	Standard	CA	Single clevis
LB	Foot	CB	Double clevis
FA	Rod side flange	TC	Center trunnion
FB	Head side flange		

### ③ Tube size

	40	50	63
Bore size	Ø40	Ø50	Ø63

### ④ Cylinder stroke

Item	Standard stroke
Bore size	
Ø40	25,50,75,100,125,150,175,200,250,300,350,400,450,500
Ø50	25,50,75,100,125,150,175,200,250,300,350,400,450,500,600
Ø63	25,50,75,100,125,150,175,200,250,300,350,400,450,500,600

※ Intermediate strokes other than standard strokes are made to order.  
 ※ Refer to page [1]-140, for specifications about custom-made rod ends.

### ⑤ Belows

	Material	Max. Temperature
Nil	Without bellows	
J	Nylon Tarpaulin	60°C
K	Neoprene Cloth	110°C

### ⑥ Rod end attachment

Nil	Rod end nut 1pc (Standard)
I	Single knuckle joint
Y	Double knuckle joint

### ⑦ Auto switch

Reed A/S	Model	Solid state A/S	Model
A54	D-A54K	F59	D-F59K
A56	D-A56K	F5P	D-F5PK
A64	D-A64K	J59	D-J59K
A90(V)	D-A90(V)K	J51	D-J51K
A93(V)	D-A93(V)K	F9N	D-F9N(V)K
A96(V)	D-A96(V)K	F9P	D-F9P(V)K
		F9B	D-F9B(V)K

※ Only for auto switch attached type.  
 ※ Refer to page [10]-9, 12, 18, 21 for more information.

### ⑧ Number of auto switches

Nil	2 pcs
S	1 pc
N	N pcs (N: 3, 4, 5...)

※ Only for auto switch attached type.

### ⑨ Special order

Nil	None
TS	Multi-step stroke cylinder(Single rod)
TW	Multi-step stroke cylinder (Double rod)
ASJ	Stroke adjustable type (in forward direction within 25mm)
BSJ	Stroke adjustable type (in forward direction within 50mm)

## Specifications

Fluid	Air
Proof pressure	14.7kgf/cm <sup>2</sup> (1.5MPa)
Max. operating pressure	9.9kgf/cm <sup>2</sup> (1.0MPa)
Min. operating pressure	0.5kgf/cm <sup>2</sup> (0.05MPa)
Ambient & fluid temperature	5~60°C
Operating piston speed	50~500mm/sec
Cushion	Both side air cushion
Tolerance of thread	KS class 2
Tolerance of stroke	~250ST: <sup>+1.0</sup> / <sub>0</sub> 251~600ST: <sup>+1.4</sup> / <sub>0</sub>
Lubrication	Not required
Degree of non-rotating rod	±0.5°
Allowable rotation torque(N·m Below)	0.44

## Precautions for installation

1. When using a rod anti-rotation cylinder, avoid using the piston rod with rotational torque. The anti-rotation guide is deformed and the degree of non-rotation increases.
2. When mounting or dismantling the work piece at the end of the rod, hold the spanner at the end of the piston rod with the piston rod fully retracted before use. At this time, tighten so that the tightening torque is not applied to the anti-rotation guide.