

HKS2510BF, 3212BF, 4014BF, 5020BF series

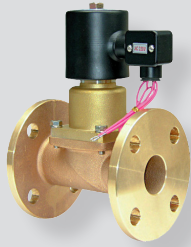

HKS 3212BF

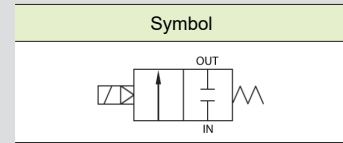

How to Order

HKS 3212 BF - AC220V

① ② ③

① Orifice

	Orifice
2510	Ø25
3212	Ø32
4014	Ø40
5020	Ø50

② Seal material

Nil	NBR	(Standard)
E	EPDM	Hot water 100 °C
M	FPM	Chemical Hot water 120 °C

③ Voltage

AC220V	AC220V 50Hz/60Hz
--------	------------------

Specifications

Classification	Standard	Option	Classification	Standard	Option
Fluid	Air, Steam, Hot water		Voltage	AC220V 50/60Hz	
Fluid temp.	0 ~ 150 °C	EPDM(100 °C) FPM(120 °C)		±10%(AC)	
Ambient temp.	50 °C (Max.)				
Pressure range	0~ 7kgf/cm ² (0 ~ 0.7MPa)		Allowable voltage fluctuation	AC : 30W	
Coil insulation	Class B		Power consumption	Brass	
Electrical connection	Terminal box Lead wire G(PF)1/2		Seal material	PTFE + SUS304 PISTON FPM + SUS304 PISTON	
End connection	JIS 10K FF		Seal Material	Refer to the table below	
Orifice	Ø25, Ø32, Ø40, Ø50		Weight	Refer to the table below	

※ Not available in explosive atmosphere.

Features

- Piston Pilot Kick type-Direct acting type
- Differential pressure 0kgf/cm² operation
- Fire resistant structure, Large capacity
- Seal material can be changed depending on fluid specifications.
- Terminal box type
- Horizontal pipe (30° or less) installation

Applications

- Building Humidifier
- Industrial washing machine
- Boiler
- Water purifier
- Sterilizer

Dimensions

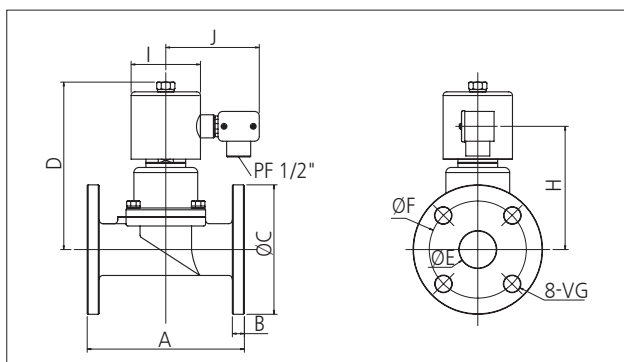

Model	A	B	C	D	E	F	G	H	I	J	Weight (kg)
HKS 2510BF	127	13	ø125	143	ø25	ø90	ø18	104	61	95	4.40
HKS 3212BF	170	13	ø135	181	ø35	ø100	ø18	133	75	102	7.70
HKS 4014BF	180	13	ø140	181	ø40	ø105	ø18	133	75	102	7.86
HKS 5020BF	180	14	ø155	186	ø50	ø120	ø18	138	75	102	9.70