

AF/ADF series



Features

- Ideal for clamping, press-in and under short stroke condition.
- Can be installed even in a narrow space with a shorter length in axial thrust direction.
- Easy installation only with bolts.
- Excellent appearance after anodizing.

Symbol	
Double Acting / Single Rod	Single Acting / Spring Return
Double Acting / Double Rod	Single Acting / Spring Extend

How to Order

AF - - S

① ② ③ ④ ⑤ ⑥ ⑦ ⑧ ⑨ ⑩ ⑪ ⑫ ⑬

① Series

AF	Single rod compact cylinder (Without magnet)
AFW	Double rod compact cylinder (Without magnet)
ADF	Single rod compact cylinder (With magnet)
ADFW	Double rod compact cylinder (With magnet)

② Type

Nil	Non-lubricated (Standard)
L	Low hydraulic pressure

③ Mounting style

Nil	Standard
LB	Foot
FA	Rod side flange
FB	Head side flange
CB	Double clevis

※ Some of the dimensions of bracket attached type is different with standard type.

※ Only applicable up to Ø12 ~ Ø100.

④ Bore size

12	Ø12	63	Ø63
16	Ø16	80	Ø80
20	Ø20	100	Ø100
25	Ø25	125	Ø125
32	Ø32	140	Ø140
40	Ø40	160	Ø160
50	Ø50	200	Ø200

⑤ Hole type

A	Both end tapped (Standard)
B	Through hole

⑦ Rod end thread

Nil	Female thread
N	Male thread

⑧ Rod end attachment

Nil	Rod end nut(Standard) : 1pc
I	Single knuckle joint
Y	Double knuckle joint

※ Only applicable up to Ø12 ~ Ø100.

※ Only rod end male thread type is applicable.

※ Please refer to page [1] -133 for change of rod end shape among custom made specifications.

⑥ Cylinder stroke

Bore size	Action	Standard stroke	
		Single rod	Double rod
Ø12		5, 10, 15, 20, 25, 30	5, 10, 15, 20, 25, 30
Ø16			
Ø20		5, 10, 15, 20, 25, 30, 35, 40, 45, 50	5, 10, 15, 20, 25, 30, 35, 40, 45, 50
Ø25			
Ø32		5, 10, 15, 20, 25, 30, 35, 40, 45, 50, 75, 100	5, 10, 15, 20, 25, 30, 35, 40, 45, 50
Ø40			
Ø50		5, 10, 15, 20, 25, 30, 35, 40, 45, 50, 75, 100	5, 10, 15, 20, 25, 30, 35, 40, 45, 50
Ø63			
Ø80			
Ø100			
Ø125			
Ø140			
Ø160			
Ø200			

※ Refer to page [1]-117, for dimensions of long stroke type (cylinder above standard stroke)

※ 55-100 strokes are put in spaces of 5, 10, 20 mm.

Ex) AF50B-S55 inserts 20mm space inside AF50B-75 (Dimensions are the same as AF50B-S75)

⑨ Auto switch

Reed A/S	Model	Solid state A/S	Model
A-72	D-A72K	F-7NV	D-F7NVK
A-73	D-A73K	F-7PV	D-F7PVK
A-80	D-A80K	F-7BV	D-F7BVK
A-90	D-A90(V)K	F-9N(V)	D-F9N(V)K
A-93	D-A93(V)K	F-9P(V)	D-F9P(V)K
A-96	D-A96(V)K	F-9B(V)	D-F9B(V)K

※ Only for auto switch attached type.

※ Refer to Auto Switch Catalogue for more information.

⑩ Number of auto switches

Nil	2 pcs
1	1 pc
N	N pcs (N:3,4,5...)

※ Only for auto switch attached type.

⑪ Cushion

Nil	None
C	Rubber bumper
A	Air cushion

※ Air cushion is only applicable to Ø32 ~ Ø80 standard stroke.

⑫ Special Order

Nil	None
TS	Multi-step stroke cylinder (Single rod)
TW	Multi-step stroke cylinder (Double rod)
ASJ	Stroke adjustable type (in forward direction within 10mm)
BSJ	Stroke adjustable type (in forward direction within 20mm)
SV	Heat resistant cylinder
E	Anti-lateral load cylinder
MS	Power Scraper cylinder (Ø32 ~ Ø80)
SS	Stainless steel piston rod

⑬ Cylinder operation type

Nil	Double acting cylinder
S	Single acting Spring return
T	Single acting Spring extend

※ Single acting type is different from double acting type, please contact us.

Specifications

Fluid	Air	
Proof pressure	14.7kgf/cm ² (1.5MPa)	
Max. operating pressure	9.9kgf/cm ² (1.0MPa)	
Min. operating pressure	Refer to the table below	
Tolerance of stroke	+1.0 0	+1.4 0
Ambient & fluid temperature	-10 ~ 70 °C (No Freezing)	
Operating piston speed	50~500mm/sec	
Cushion	Ø12~Ø100 : No cushion	Ø125, Ø140, Ø160 : Basic with rubber cushion
Tolerance of thread	KS class 2	
Rod end thread	Female thread (Standard), Male thread	

※ Low hydraulic pressure type and standard type have the same dimensions.

Min. operating pressure

Bore size	Ø12	Ø16	Ø20	Ø25	Ø32	Ø40	Ø50	Ø63	Ø80	Ø100	Ø125	Ø140	Ø160	Ø200
Double acting	0.7	0.7	0.5	0.5	0.5	0.5	0.5	0.5	0.5	0.5	0.5	0.5	0.5	0.5
Single acting (Spring return, Spring extend)	2.5	2.5	1.8	1.8	1.7	1.5	1.3	-	-	-	-	-	-	-

Min. Stroke for Auto Switch

Number of auto switch	Min. stroke
1 pc	5mm
2 pcs	10mm

※ Only for ADF series(Magnet attached type).

Accessory

Type	Accessory	Double acting single rod				
		Standard	Foot	Rod side flange	Head side flange	Double clevis
Standard	Rod end nut	●	●	●	●	●
	Clevis pin	-	-	-	-	●
Option	Single knuckle joint	●	●	●	●	●
	Double knuckle joint	●	●	●	●	●

- ※ For double clevis and double knuckle joint, pin and snap ring are included.
- ※ Every mounting bracket includes a hex-wrench bolt.
- ※ Rod end nut is only applicable to male thread type.

Mounting Bracket

Mounting	Bore size	Ø12	Ø16	Ø20	Ø25	Ø32	Ø40	Ø50	Ø63
	Foot		LB(CP)12	LB(CP)16	LB(CP)20	LB(CP)25	LB(CP)32	LB(CP)40	LB(CP)50
Flange		FA/FB(CP)12	FA/FB(CP)16	FA/FB(CP)20	FA/FB(CP)25	FA/FB(CP)32	FA/FB(CP)40	FA/FB(CP)50	FA/FB(CP)63
Double clevis (with pin)		CB(CP)12	CB(CP)16	CB(CP)20	CB(CP)25	CB(CP)32	CB(CP)40	CB(CP)50	CB(CP)63

Mounting	Bore size	Ø80	Ø100	Ø125	Ø140	Ø160	Ø200
	Foot		LB(CP)80	LB(CP)100	-	-	-
Flange		FA/FB(CP)80	FA/FB(CP)100	-	-	-	-
Double clevis (with pin)		CB(CP)80	CB(CP)100	-	-	-	-

※ For foot mounting, 2pcs in one set.

Rod End Attachment

Bore size(mm) Attachment	Ø12	Ø16	Ø20	Ø25	Ø32,Ø40	Ø50,Ø63	Ø80	Ø100	Ø125	Ø140	Ø160	Ø200
Single knuckle joint	I(CP)12	I(CP)16	I(CP)20	I(CP)25	I(CP)32,40	I(CP)50,63	I(CP)80	I(CP)100	-	-	-	-
Double knuckle joint	Y(CP)12	Y(CP)16	Y(CP)20	Y(CP)25	Y(CP)32,40	Y(CP)50,63	Y(CP)80	Y(CP)100	-	-	-	-
Rod end nut	RN(CP)12	RN(CP)16	RN(CP)20	RN(CP)25	RN(CP)32,40	RN(CP)50,63	RN(CP)80	RN(CP)100	-	-	-	-

Auto Switch Attachment

Ø12~Ø25

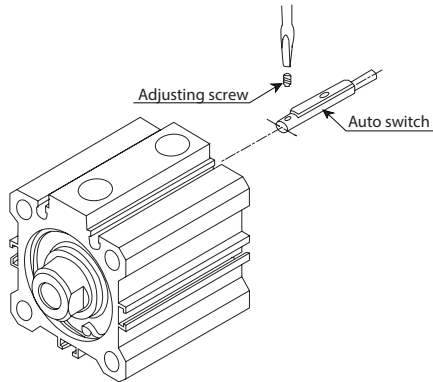

Ø12~Ø125 (Standard)

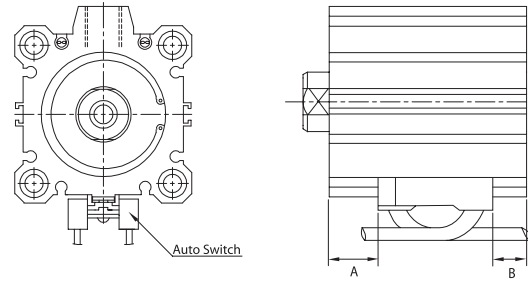

Ø20~Ø125

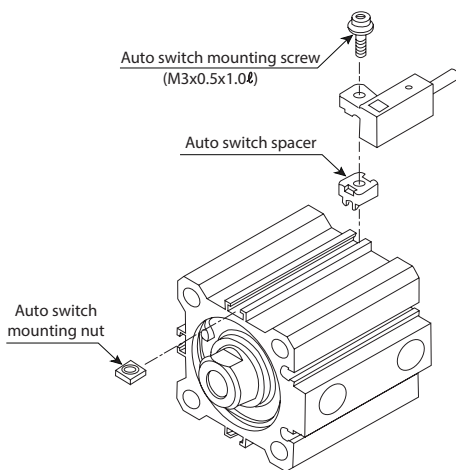

Unit : mm

Bore size	A	B
Ø12	7.5	3
Ø16	7.5	3
Ø20	8	6.5
Ø25	8	6.5
Ø32	9.5	7
Ø40	13.5	9.5
Ø50	13.5	12.5
Ø63	14	15.5
Ø80	17	20
Ø100	21.5	25
Ø125	32.5	32.5
Ø140	36	38.5
Ø160	42	44
Ø200		

※ For 5mm stroke cylinder(with 1 auto switch) or 10mm stroke cylinder (with 2 auto switches) when auto switch/auto switches do not turn off or both switches turn on simultaneously, mount the auto switch 1~2mm more toward.

Mass

AF Series

Unit : g

Cylinder stroke	Bore size										
	Ø12	Ø16	Ø20	Ø25	Ø32	Ø40	Ø50	Ø63	Ø80	Ø100	
5	29	42	63	86	125	187	-	-	-	-	
10	35	50	75	100	145	208	339	480	916	1608	
15	41	59	88	115	165	230	372	518	976	1688	
20	47	67	101	129	184	251	405	556	1036	1768	
25	54	76	114	144	204	273	438	594	1097	1849	
30	60	84	127	158	224	294	471	632	1157	1929	
35	-	-	140	173	244	315	504	670	1217	2010	
40	-	-	152	187	263	337	537	708	127	2090	
45	-	-	165	202	283	358	570	748	1338	2170	
50	-	-	178	216	303	380	603	784	1398	2251	
75	-	-	-	-	459	575	891	1129	1941	3018	
100	-	-	-	-	558	687	1062	1326	2237	3426	
Both end tapped	2	2	6	6	6	6	6	19	45	45	
Rod end male thread	Male thread part	1.5	3	6	12	26	27	53	53	120	175
	Nut	1	2	4	8	17	17	32	32	49	116
Rubber bumper attached	0	0	-2	-3	-3	-7	-9	-18	-31	-56	
Foot	55	67	164	186	142	154	243	317	683	1052	
Rod side flange	57	69	139	161	180	214	373	534	1056	1365	
Head side flange	54	65	133	152	165	198	348	534	1017	1309	
Double clevis	32	39	88	123	151	196	393	554	1109	1887	

* For foot, rod side flange, and head side flange mounting, bolt is included.
* Double clevis includes a pin, a snap ring and bolt.

ADF Series

Unit : g

Cylinder stroke	Bore size									
	Ø12	Ø16	Ø20	Ø25	Ø32	Ø40	Ø50	Ø63	Ø80	Ø100
5	43	64	94	134	182	269	-	-	-	-
10	49	71	106	149	202	290	455	627	1162	1966
15	55	79	118	164	222	312	488	665	1222	2047
20	61	87	131	180	241	333	521	703	1282	2127
25	67	95	143	195	261	355	554	741	1342	2208
30	73	102	155	210	281	376	587	779	1403	2288
35	-	-	167	226	300	398	620	817	1463	2368
40	-	-	179	241	320	420	653	855	1524	2449
45	-	-	191	256	340	441	686	893	1584	2529
50	-	-	203	272	359	463	719	931	1644	2610
75	-	-	-	-	459	575	891	1129	1941	3018
100	-	-	-	-	558	687	1062	1326	2237	3426

Calculation:

1. AF

Ex) AF-CB32A-S20NC

Basic mass: 184 / Both end tapped type: 6 / Rod end male thread: 43
Rubber bumper: -3 / Double clevis: 151
 $184 + 6 + 43 - 3 + 151 = 381g$

2. ADF

Ex) ADF-CB32A-S20NC

Basic mass: 241 / Both end tapped type: 6 / Rod end male thread: 43
Rubber bumper: -3 / Double clevis: 151
 $241 + 6 + 43 - 3 + 151 = 381g$

AFW Series

Unit : g

Cylinder stroke	Bore size										
	Ø12	Ø16	Ø20	Ø25	Ø32	Ø40	Ø50	Ø63	Ø80	Ø100	
5	42	59	89	119	185	279	-	-	-	-	
10	49	68	104	136	212	308	497	646	1149	1960	
15	56	77	119	153	235	337	538	682	1225	2068	
20	63	86	134	170	257	367	580	718	1302	2177	
25	70	95	149	187	280	396	622	754	1378	2286	
30	77	104	164	204	303	426	664	790	1455	2394	
35	-	-	179	221	326	455	705	826	1531	2503	
40	-	-	194	238	349	484	747	862	1608	2612	
45	-	-	209	255	372	514	789	899	1684	2720	
50	-	-	224	272	395	543	830	935	1760	2829	
75	-	-	-	-	558	765	1073	1346	2387	3746	
100	-	-	-	-	673	912	1252	1556	2769	4289	
Both end tapped	2	2	6	6	6	6	6	19	45	45	
Rod end male thread	Male thread part	3	6	12	24	52	54	106	106	240	350
	Nut	2	4	8	16	34	34	64	64	98	232
Rubber bumper attached	0	0	-2	-2	-3	-7	-12	-20	-34	-57	

* Mounting bolt is included for foot, head side flange type.

ADFW Seires

Unit : g

Cylinder stroke	Bore size									
	Ø12	Ø16	Ø20	Ø25	Ø32	Ø40	Ø50	Ø63	Ø80	Ø100
5	50	77	120	170	238	353	-	-	-	-
10	58	87	136	185	260	383	609	798	1393	2334
15	65	96	151	201	283	412	645	840	1469	2443
20	73	106	166	216	306	442	681	882	1546	2551
25	80	115	182	232	329	471	716	924	1622	2660
30	87	125	197	247	352	500	752	966	1699	2769
35	-	-	212	263	375	530	788	1008	1775	2877
40	-	-	228	279	398	559	823	1051	1851	2986
45	-	-	243	294	421	589	859	1093	1928	3094
50	-	-	258	310	444	618	895	1135	2004	3203
75	-	-	-	-	558	765	1073	1346	2387	3746
100	-	-	-	-	673	912	1252	1556	2769	4289

Calculation:

1. AFW

Ex) AFW-CB32A-S20NC

Basic mass: 257 / Both end tapped type: 6 / Rod end male thread: 86
Rubber bumper: -3 / Double clevis: 180
 $257 + 6 + 86 - 3 + 180 = 526g$

2. ADFW

Ex) ADFW-CB32A-S20NC

Basic mass: 306 / Both end tapped type: 6 / Rod end male thread: 86
Rubber bumper: -3 / Double clevis: 180
 $306 + 6 + 86 - 3 + 180 = 575g$

Structure

Single Rod, Double Acting

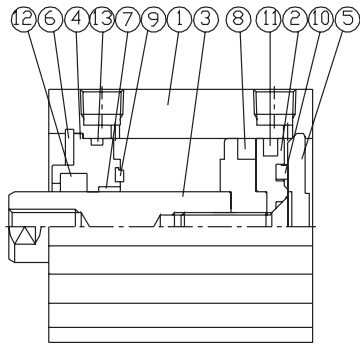

For both AF/ADF series.
Part #9, #10 are only for rubber bumper attached cylinder.

Double Rod, Double Acting

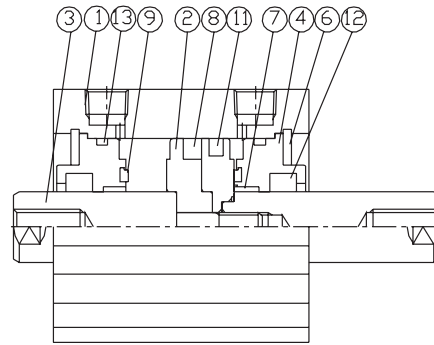

For both AF/ADF series

Single Acting Spring Return

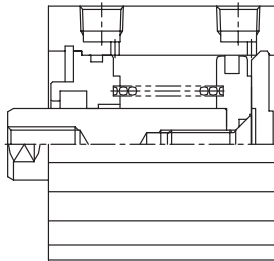

Only for AF series

Single Acting Spring Extend

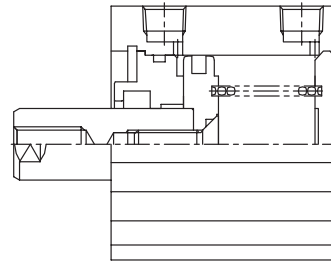

Only for AF series

No.	Parts	Material	Remark
1	Cylinder Tube	AL Alloy	Hard Anodized Aluminium
2	Piston	AL Alloy	-
3	Piston Rod	Stainless Steel: $\phi 12 \sim \phi 25$	Hard Chromium Plating
		Carbon Steel: $\phi 32 \sim \phi 125$	
4	Rod Cover	Brass: $\phi 12 \sim \phi 32$	White Anodizing
		Al $\phi 40 \sim \phi 125$	
5	Head Cover	AL Alloy	White Anodizing
6	Snap Ring	Spring Steel	-
7	Bush	Copper	-
8	Magnet	-	Only for Auto Switch Attached type
9	Cushion Damper A	Urethane	-
10	Cushion Damper B	Urethane	-

No.	Parts	Material	Bore size												
			$\phi 12$	$\phi 16$	$\phi 20$	$\phi 25$	$\phi 32$	$\phi 40$	$\phi 50$	$\phi 63$	$\phi 80$	$\phi 100$	$\phi 125$	$\phi 140$	$\phi 160$
11	Piston Packing	NBR	OPA12	OPA16	OPA20	OPA25	OPA32	OPA40	OPA50	OPA63	OPA80	OPA100	OPA125	OPA140	OPA160
12	Rod Packing	NBR	DYR6K	DYR8K	DYR10K	DYR12K	DYR16K	DRP16	DRP20	DRP20	DRP25	DRP30	DRP35	ORA35	ORA40
13	Tube O-Ring	NBR	S-10	S-14	S-18	S-22	S-29	S-37	S-46	S-60	S-75	S-95	S-120	S-135	S-156

Structure-Air Cushion Option

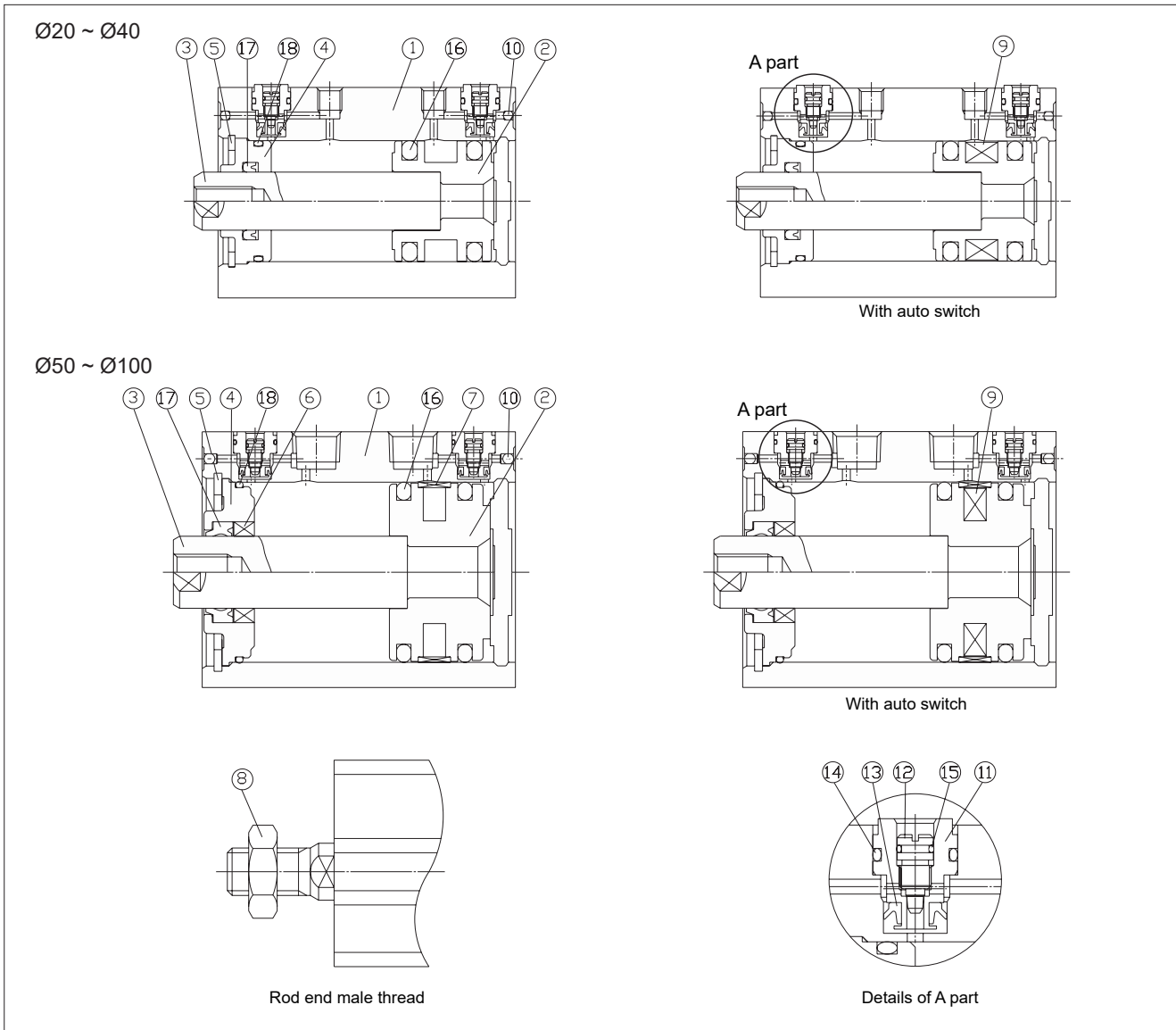

No.	Parts	Material	Remark
1	Cylinder Tube	AL Alloy	Hard Anodized
2	Piston	AL Alloy	-
3	Piston Rod	Stainless Steel	Ø20, Ø25
		Carbon Steel	Ø32~Ø100, Hard Chrome Plated
4	Rod Cover	Brass : Ø12 ~ Ø32	-
		Aluminum : Ø40~Ø100	White Anodizing
5	Snap ring	Carbon Steel	-
6	Bush	Bearing Alloy	Ø50~Ø100
7	Wear Ring	Resin	-
8	Rod End Nut	Carbon Steel	-

No.	Parts	Material	Remark
9	Magnet	-	-
10	Steel Ball	Chrome Bearing Steel	-
11	Check Case	Brass	Electroless Nickel Plated
12	Cushion Needle	NBR	-
13	Packing	NBR	-
14	O-ring	NBR	-
15	O-ring	NBR	-

No.	Parts	Material	Bore size							
			Ø20	Ø25	Ø32	Ø40	Ø50	Ø63	Ø80	Ø100
16	Piston Seal	NBR	OPA20	OPA25	OPA32	OPA40	OPA50	OPA63	OPA80	OPA100
17	Rod Seal	NBR	DYR10K	DYR12K	DYR16K	DRP16	DRP20	DRP20	DRP25	DRP30
18	Tube O-ring	NBR	S-18	S-22	S-29	S-37	S-46	S-60	S-75	S-95

Dimensions-Standard Ø12, Ø16, Ø20, Ø25

Rod End-Female Thread (Standard)

Ø12

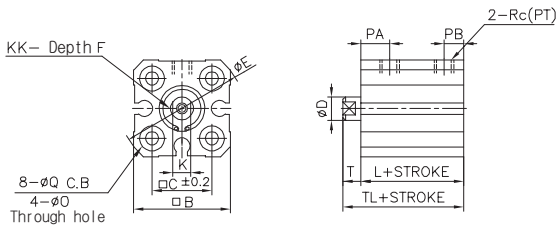

Ø16

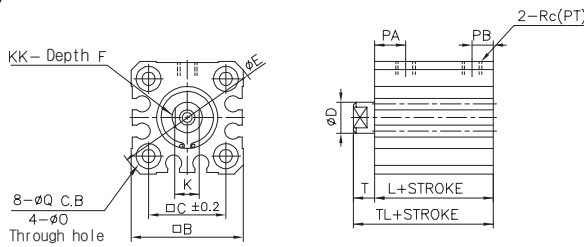

Ø20 ~ Ø25

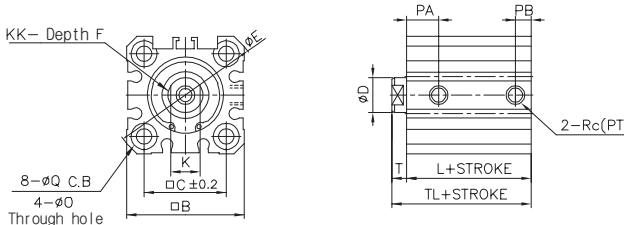

Rod End-Male Thread

Ø12

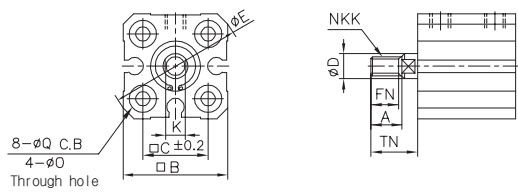

Ø16

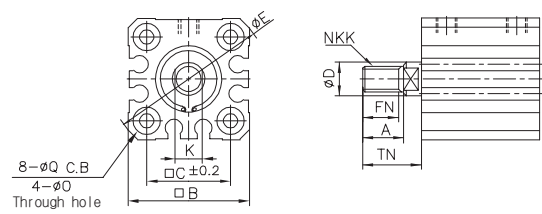

Ø20 ~ Ø25

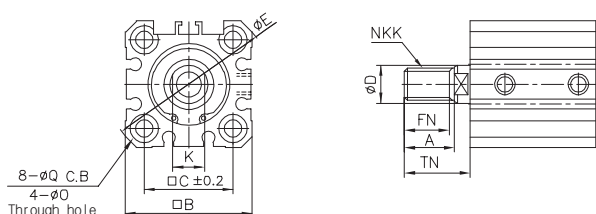

Unit : mm

Bore size	Stroke	Without magnet (AF)			With magnet (ADF)			A	□B	□C	ØD	ØE	F	FN
		L	PA	TL	L	PA	TL							
Ø12	5~30	17	7.5	20.5	28	10	31.5	10.5	25	15.5	6	32	6	9
Ø16	5~30	18.5	8	22	30.5	10	34	12	29	20	8	38	8	10
Ø20	5~50	19.5	10.5	24	31.5	10.5	36	14	36	25.5	10	47	8	12
Ø25	5~50	22.5	11	27.5	32.5	11	37.5	17.5	40	28	12	52	12	15

Bore size	K	KK	NKK	ØO	PB	ØQ	Rc(PT)	T	TN
Ø12	5	M3X0.5	M5X0.8	3.5	5	6.5 Depth 3.5	M5X0.8	3.5	14
Ø16	6	M4X0.7	M6X1.0	3.5	5.5	6.5 Depth 3.5	M5X0.8	3.5	15.5
Ø20	8	M5X0.8	M8X1.25	5.5	6	9 Depth 7	M5X0.8	4.5	18.5
Ø25	10	M6X1.0	M10X1.25	5.5	5.5	9 Depth 7	M5X0.8	5	22.5

Both End Tapped (Standard)

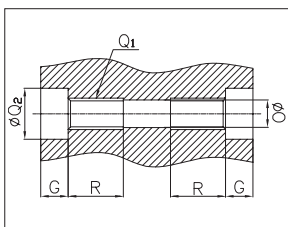

Unit : mm

Bore size	G	Q ₁	ØQ ₂	R
Ø12	3.5	M4X0.7	6.5	7
Ø16	3.5	M4X0.7	6.5	7
Ø20	7	M6X1.0	9	10
Ø25	7	M6X1.0	9	10

Dimensions-Standard Ø32~Ø160

Rod End-Female Thread (Standard)

Ø32 ~ Ø160

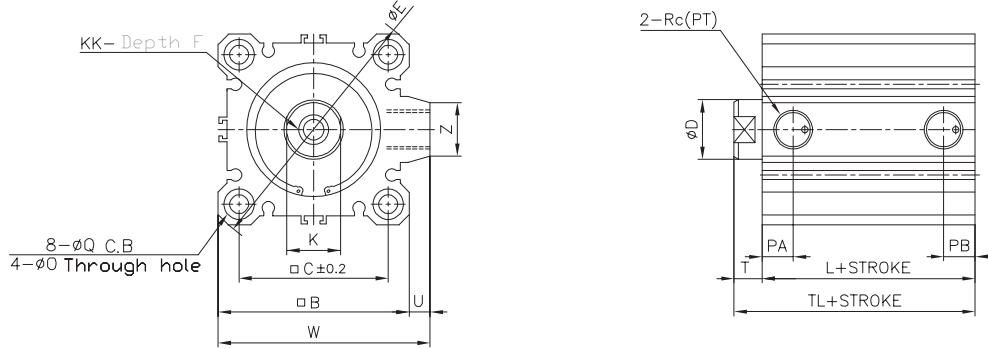

Rod End-Male Thread

Ø32 ~ Ø160

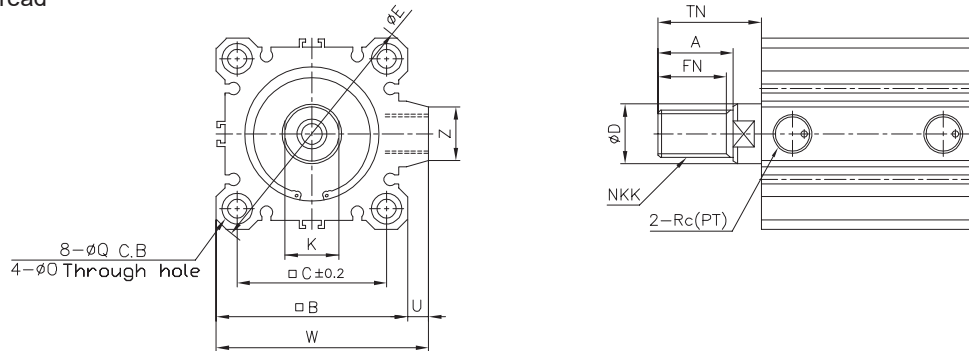

Unit : mm

Bore size	Stroke	Without magnet (AF)		With magnet (ADF)		A	□B	□C	ØD	ØE	F	FN	K	KK	NKK	ØO	PA	PB	ØQ
		L	TL	L	TL														
Ø32	5																11.5	5.5	9 Depth 7
	10~50	23	30	33	40	23.5	45	34	16	60	13	20.5	14	M8X1.25	M14X1.5	5.5	10.5	7.5	
	75,100	33	40																
Ø40	5~50	29.5	36.5	39.5	46.5	23.5	52	40	16	69	13	20.5	14	M8X1.25	M14X1.5	5.5	12	8.5	9 Depth 7
	75,100	39.5	46.5																
	5~50	30.5	38.5	40.5	48.5	28.5	64	50	20	86	15	26	18	M10X1.5	M18X1.5	6.8	10.5	10.5	
75,100	40.5	48.5																	
Ø50	5~50	36	44	46	54	28.5	77	60	20	103	15	26	18	M10X1.5	M18X1.5	9	15	11	14 Depth 10.5
	75,100	46	54																
	Ø63	5~50	43.5	53.5	53.5	63.5	35.5	98	77	25	132	21	32.5	22	M16X2.0	M22X1.5	11	18	
75,100		53.5	63.5																
5~50		53	65	63	75	35.5	117	94	30	156	27	32.5	27	M20X2.5	M26X1.5	11	23	13	
75,100	63	75																	
Ø100	10~300	83	99	83	99	45	142	114	35	190	30	42	30	M22X2.5	M30X1.5	12.5	24.5	24.5	21.2 Depth 18.4
Ø125	10~300	83	99	83	99	45	158	128	35	210	30	42	30	M22X2.5	M30X1.5	12.5	24.5	24.5	21.2 Depth 18.4
Ø160	10~300	91	108	91	108	50	178	144	40	238	33	47	36	M24X3	M36X1.5	14.5	27.5	27.5	24.2 Depth 21.2

Unit: mm

Bore size	Rc(PT)	T	TN	U	W	Z
Ø32	M5X0.8 (5st)	7	28.5	4.5	49.5	14
	Rc(PT)1/8					
Ø40	Rc(PT)1/8	7	28.5	5	57	14
Ø50	Rc(PT)1/4	8	33.5	7	71	18
Ø63	Rc(PT)1/4	8	33.5	7	84	18
Ø80	Rc(PT)3/8	10	43.5	6	104	22
Ø100	Rc(PT)3/8	12	43.5	6.5	123.5	22
Ø125	Rc(PT)3/8	16	58	11	153	32
Ø140	Rc(PT)3/8	16	58	10	168	32
Ø160	Rc(PT)3/8	17	64	10	188	32

Both End Tapped (Standard)

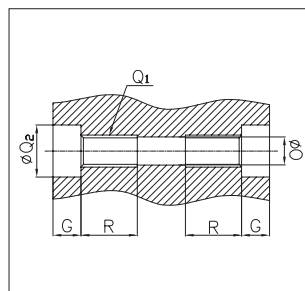

Unit : mm

Bore size	G	Q ₁	ØQ ₂	R
Ø32	7	M6X1.0	9	10
Ø40	7	M6X1.0	9	10
Ø50	8	M8X1.25	11	14
Ø63	10.5	M10X1.50	14	18
Ø80	13.5	M12X1.75	17.5	22
Ø100	13.5	M12X1.75	17.5	22
Ø125	18.4	M14X2.0	21.2	25
Ø140	18.4	M14X2.0	21.2	25
Ø160	21.2	M16X2.0	24.2	28

Dimensions-Standard Ø200

Rod End-Female Thread (Standard/ Single rod)

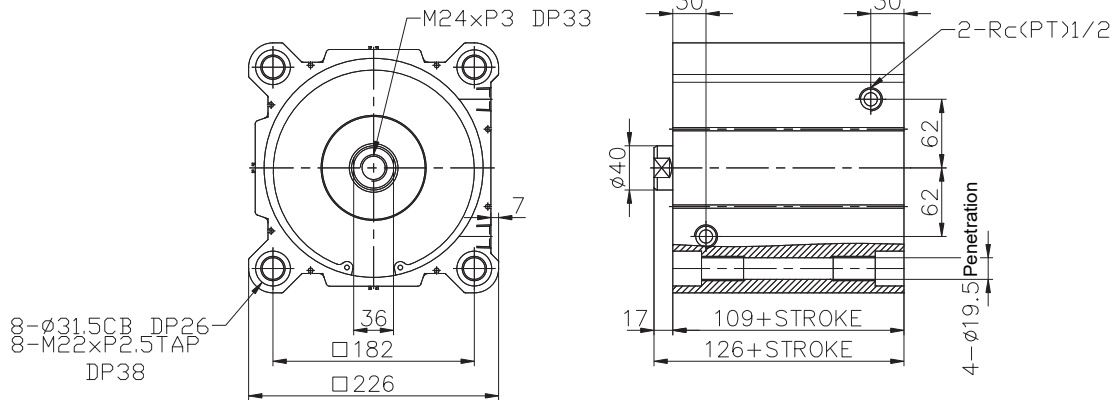

If the number is less than 20, penetrate through 8-M22xP2.5 TAP

Rod End-Male Thread

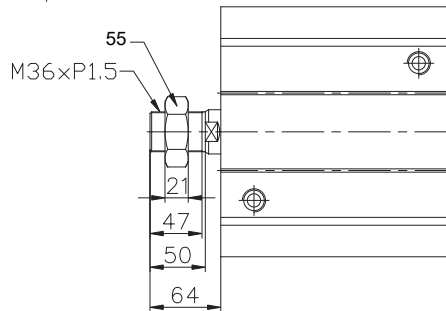

Rod End-Female Thread (Standard/ Double rod)

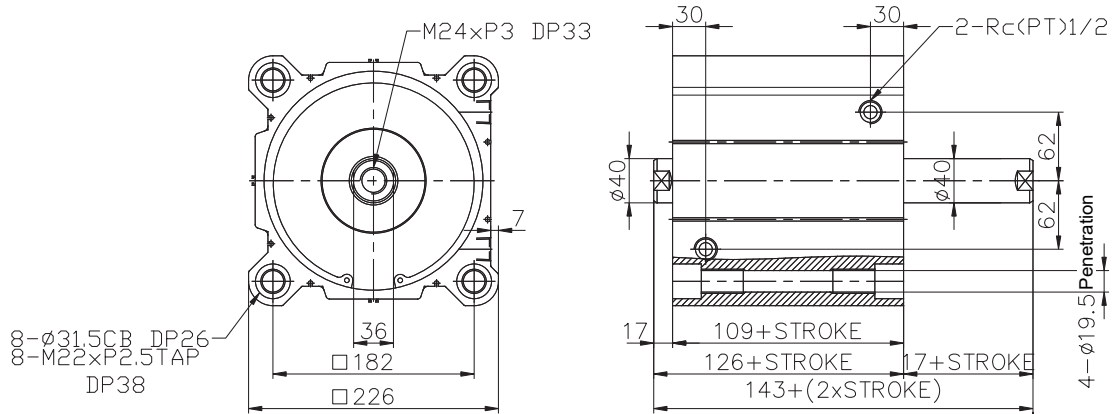

If the number is less than 20, penetrate through 8-M22xP2.5 TAP

Rod End-Male Thread

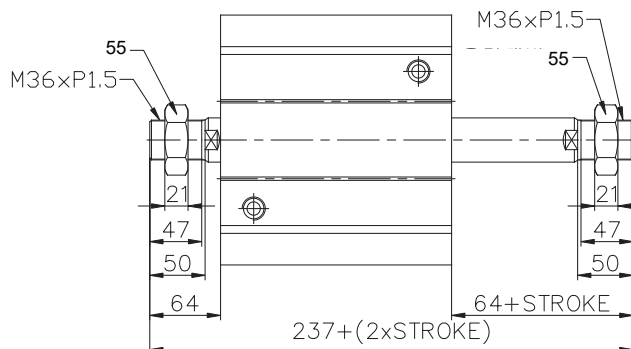

Dimensions-Foot (LB)

Bore size : Ø12, Ø16, Ø20, Ø25

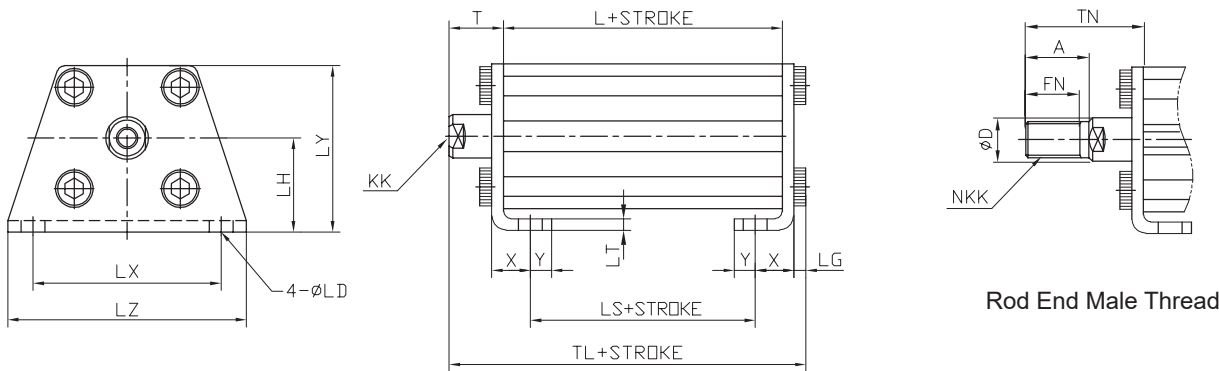

Unit : mm

Bore size	Without magnet (AF)			With magnet (ADF)			A	ØD	FN	LD	LG	LH	LT	LX	LY	LZ	KK	NKK	T	TN	X	Y
	TL	L	LS	TL	L	LS																
Ø12	35.3	17	5	46.3	28	16	10.5	6	9	4.5	2.8	17	2	34	29.5	44	M3X0.5	M5X0.8	13.5	24	8	4.5
Ø16	36.8	18.5	6.5	48.8	30.5	18.5	12	8	10	4.5	2.8	19	2	38	33.5	48	M4X0.7	M6X1.0	13.5	25.5	8	5
Ø20	41.2	19.5	7.5	53.2	31.5	19.5	14	10	12	6.6	4	24	3.2	48	42	62	M5X0.8	M8X1.25	14.5	28.5	9.2	5.8
Ø25	44.7	22.5	7.5	54.7	32.5	17.5	17.5	12	15	6.6	4	26	3.2	52	46	66	M6X1.0	M10X1.25	15	32.5	10.7	5.8

Bore size : Ø32, Ø40, Ø50, Ø63, Ø80, Ø100

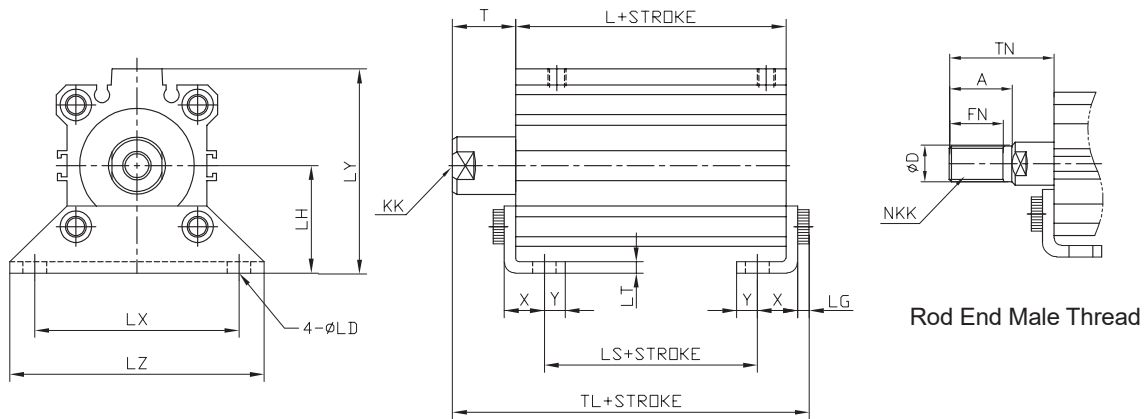

Unit : mm

Bore size	Stroke	Without magnet (AF)			With magnet (ADF)			A	ØD	FN	LD	LG	LH	LT	LX	LY	LZ	KK	NKK	T	TN	X	Y
		TL	L	LS	TL	L	LS																
Ø32	5~50	47.2	23	7	57.2	33	17	23.5	16	20.5	6.6	4	30	3.2	57	57	71	M8X1.25	M14X1.5	17	38.5	11.2	5.8
	75,100	57.2	33	17																			
Ø40	5~50	53.7	29.5	13.5	63.7	39.5	23.5	23.5	16	20.5	6.6	4	33	3.2	64	64	78	M8X1.25	M14X1.5	17	38.5	11.2	7
	75,100	63.7	39.5	23.5																			
Ø50	5~50	56.7	30.5	7.5	66.7	40.5	17.5	28.5	20	26	9	5	39	3.2	79	78	95	M10X1.5	M18X1.5	18	43.5	14.7	8
	75,100	66.7	40.5	17.5																			
Ø63	5~50	63.2	36	10	73.2	46	20	28.5	20	26	11	6	46	3.2	95	91.5	113	M10X1.5	M18X1.5	18	43.5	16.2	9
	75,100	73.2	46	20																			
Ø80	5~50	75	43.5	13.5	85	53.5	23.5	35.5	25	32.5	13	7	59	4.5	118	114	140	M16X2.0	M22X1.5	20	53.5	19.5	11
	75,100	85	53.5	23.5																			
Ø100	5~50	88	53	19	98	63	29	35.5	30	32.5	13	7	71	6	137	136	162	M20X2.5	M26X1.5	22	53.5	23	12.5
	75,100	98	63	29																			

Dimensions-Rod Side Flange (FA)

Bore size : Ø12, Ø16, Ø20, Ø25

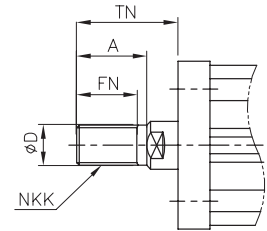
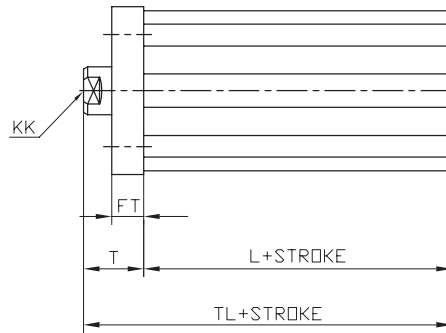
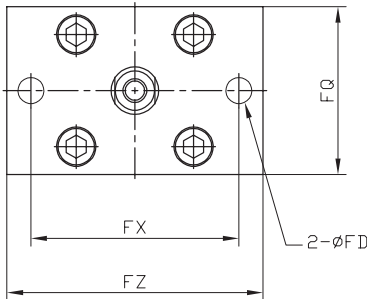

Rod End Male Thread

Unit : mm

Bore size	Stroke	Without magnet (AF)		With magnet (ADF)		A	ØD	FD	FN	FQ	FT	FX	FZ	KK	NKK	T	TN
		TL	L	TL	L												
Ø12	5~30	30.5	17	41.5	28	10.5	6	4.5	9	25	5.5	45	55	M3X0.5	M5X0.8	13.5	24
Ø16	5~30	32	18.5	44	30.5	12	8	4.5	10	30	5.5	45	55	M4X0.7	M6X1.0	13.5	25.5
Ø20	5~50	34	19.5	46	31.5	14	10	6.6	12	39	8	48	60	M5X0.8	M8X1.25	14.5	28.5
Ø25	5~50	37.5	22.5	47.5	32.5	17.5	12	6.6	15	42	8	52	64	M6X1.0	M10X1.25	15	32.5

Bore size : Ø32, Ø40, Ø50, Ø63, Ø80, Ø100

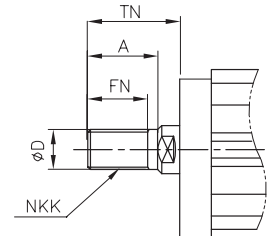
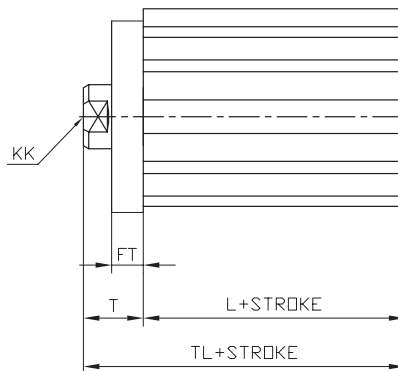
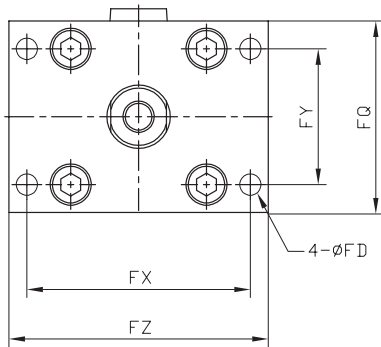

Rod End Male Thread

Unit : mm

Bore size	Stroke	Without magnet (AF)		With magnet (ADF)		A	ØD	FD	FN	FQ	FT	FX	FY	FZ	KK	NKK	T	TN
		TL	L	TL	L													
Ø32	5~50	40	23	50	33	23.5	16	5.5	20.5	48	8	56	34	65	M8X1.25	M14X1.5	17	38.5
	75,100	50	33															
Ø40	5~50	46.5	29.5	56.5	39.5	23.5	16	5.5	20.5	54	8	62	40	72	M8X1.25	M14X1.5	17	38.5
	75,100	56.5	39.5															
Ø50	5~50	48.5	30.5	58.5	40.5	28.5	20	6.6	26	67	9	76	50	89	M10X1.5	M18X1.5	18	43.5
	75,100	58.5	40.5															
Ø63	5~50	54	36	64	46	28.5	20	9	26	80	9	92	60	108	M10X1.5	M18X1.5	18	43.5
	75,100	64	46															
Ø80	5~50	63.5	43.5	73.5	53.5	35.5	25	11	32.5	99	11	116	77	134	M16X2.0	M22X1.5	20	53.5
	75,100	73.5	53.5															
Ø100	5~50	75	53	85	63	35.5	30	11	32.5	117	11	136	94	154	M20X2.5	M26X1.5	22	53.5
	75,100	85	63															

Dimensions-Head Side Flange (FB)

Bore size : Ø12, Ø16, Ø20, Ø25

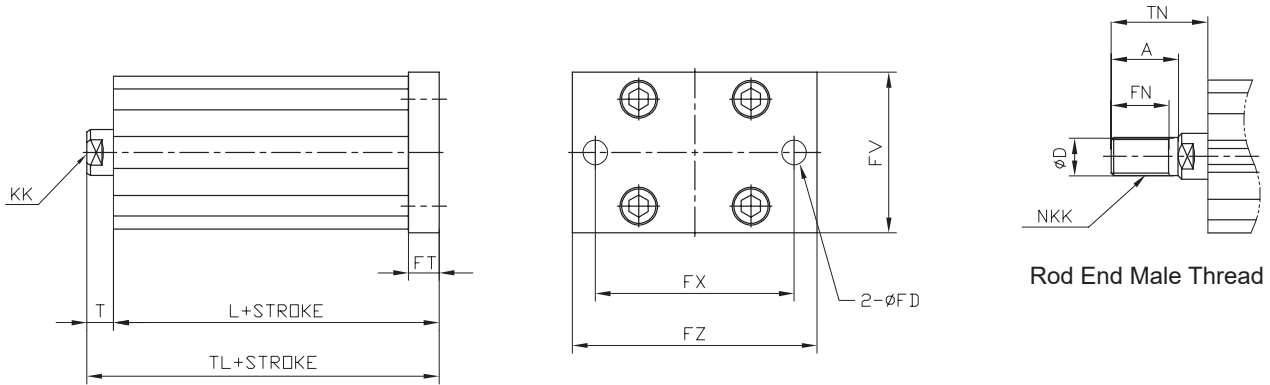

Unit : mm

Bore size	Stroke	Without magnet (AF)		With magnet (ADF)		A	ØD	FD	FN	FT	FV	FX	FZ	KK	NKK	T	TN
		TL	L	TL	L												
Ø12	5~30	26	17	37	28	10.5	6	4.5	9	5.5	25	45	55	M3X0.5	M5X0.8	3.5	14
Ø16	5~30	27.5	18.5	39.5	30.5	12	8	4.5	10	5.5	30	45	55	M4X0.7	M6X1.0	3.5	15.5
Ø20	5~50	32	19.5	44	31.5	14	10	6.6	12	8	39	48	60	M5X0.8	M8X1.25	4.5	18.5
Ø25	5~50	35.5	22.5	45.5	32.5	17.5	12	6.6	15	8	42	52	64	M6X1.0	M10X1.25	5	22.5

Bore size : Ø32, Ø40, Ø50, Ø63, Ø80, Ø100

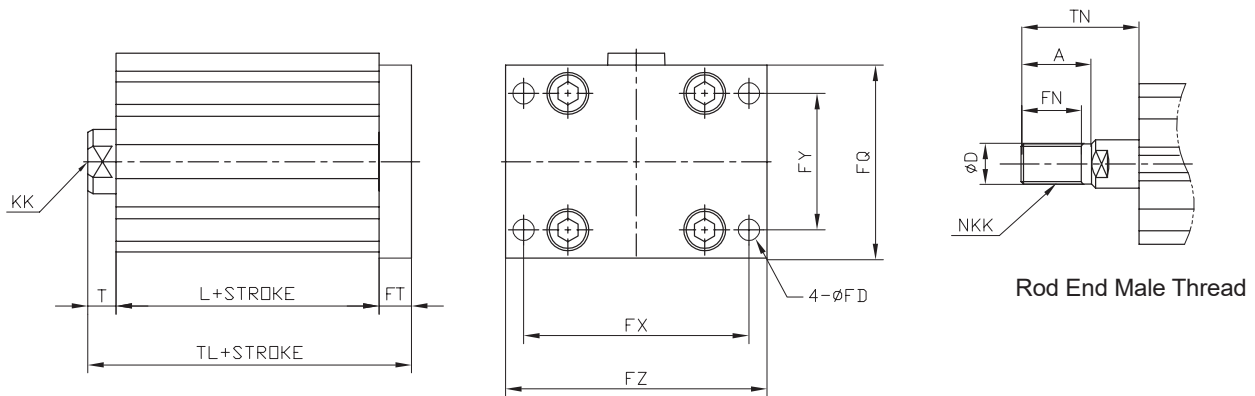

Unit : mm

Bore size	Stroke	Without magnet (AF)		With magnet (ADF)		A	ØD	FD	FN	FQ	FT	FX	FY	FZ	KK	NKK	T	TN
		TL	L	TL	L													
Ø32	5~50	38	23	48	33	23.5	16	5.5	20.5	48	8	56	34	65	M8X1.25	M14X1.5	7	28.5
	75,100	48	33															
Ø40	5~50	44.5	29.5	54.5	39.5	23.5	16	5.5	20.5	54	8	62	40	72	M8X1.25	M14X1.5	7	28.5
	75,100	54.5	39.5															
Ø50	5~50	47.5	30.5	57.5	40.5	28.5	20	6.6	26	67	9	76	50	89	M10X1.5	M18X1.5	8	33.5
	75,100	57.5	40.5															
Ø63	5~50	53	36	63	46	28.5	20	9	26	80	9	92	60	108	M10X1.5	M18X1.5	8	33.5
	75,100	63	46															
Ø80	5~50	64.5	43.5	74.5	53.5	35.5	25	11	32.5	99	11	116	77	134	M16X2.0	M22X1.5	10	43.5
	75,100	74.5	53.5															
Ø100	5~50	76	53	86	63	35.5	30	11	32.5	117	11	136	94	154	M20X2.5	M26X1.5	12	43.5
	75,100	86	63															

Dimensions-Double Clevis (CB)

Bore size : Ø12, Ø16, Ø20, Ø25

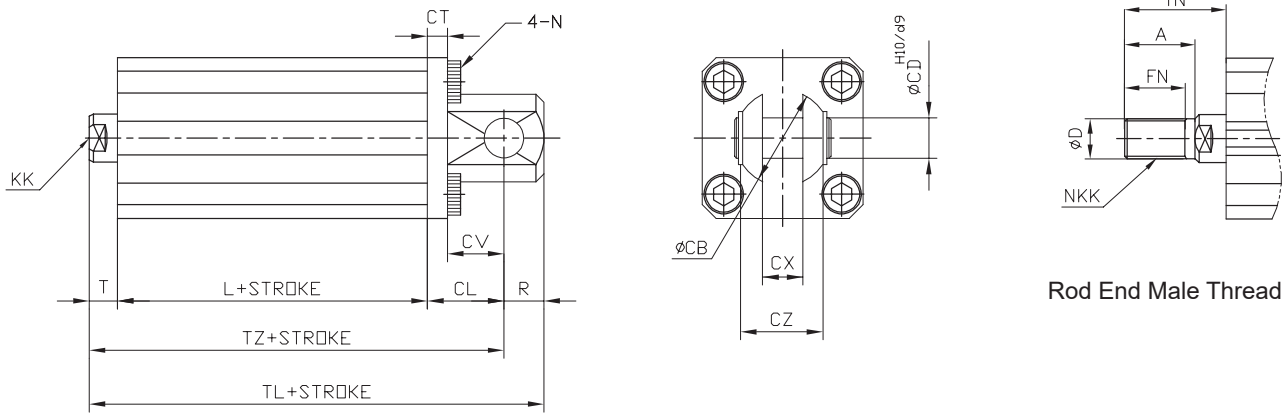

Unit : mm

Bore size	Stroke	Without magnet (AF)			With magnet (ADF)			A	ØD	FN	CB	CD	CL	CT	CV	CX	CZ	KK	N	NKK	R	T	TN
		TL	L	TZ	TL	L	TZ																
Ø12	5~30	40.5	17	34.5	51.5	28	45.5	10.5	6	9	12	5	14	4	7	5	10	M3X0.5	M4XP0.7	M5X0.8	6	3.5	14
Ø16	5~30	43	18.5	37	55	30.5	49	12	8	10	14	5	15	4	10	6.5	12	M4X0.7	M4XP0.7	M6X1.0	6	3.5	15.5
Ø20	5~50	51	19.5	42	63	31.5	54	14	10	12	20	8	18	5	12	8	16	M5X0.8	M6XP1.0	M8X1.25	9	4.5	18.5
Ø25	5~50	57.5	22.5	47.5	67.5	32.5	57.5	17.5	12	15	24	10	20	5	14	10	20	M6X1.0	M6XP1.0	M10X1.25	10	5	22.5

Bore size : Ø32, Ø40, Ø50, Ø63, Ø80, Ø100

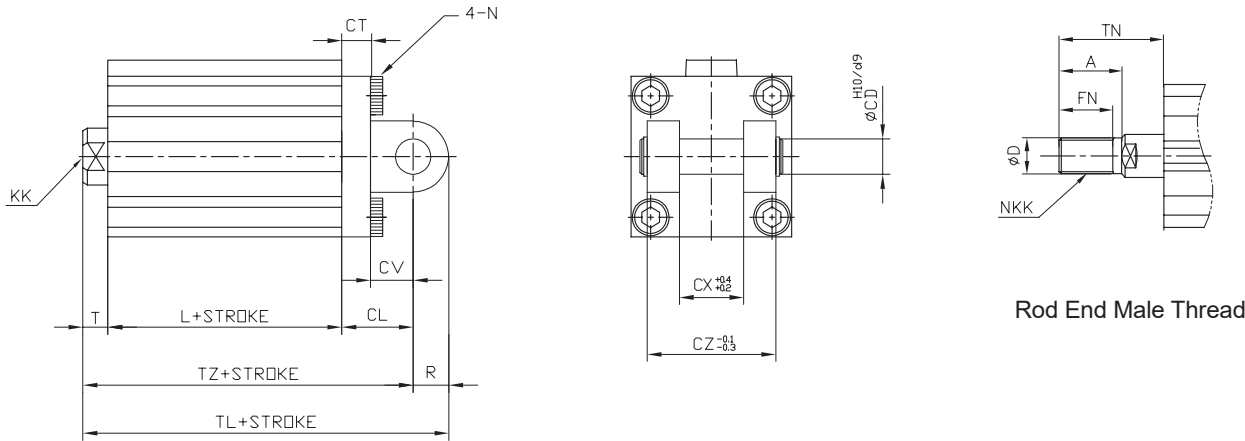

Unit : mm

Bore size	Stroke	Without magnet (AF)			With magnet (ADF)			A	CD	CL	CT	CV	CX	CZ	ØD	FN	KK	N	NKK	R	T	TN
		TL	L	TZ	TL	L	TZ															
Ø32	5~50	60	23	50	70	33	60	23.5	10	20	5	14	18	36	16	20.5	M8X1.25	M6XP1.0	M14X1.5	10	7	28.5
	75,100	70	33	60																		
Ø40	5~50	68.5	29.5	58.5	78.5	39.5	68.5	23.5	10	22	6	14	18	36	16	20.5	M8X1.25	M6XP1.0	M14X1.5	10	7	28.5
	75,100	78.5	39.5	68.5																		
Ø50	5~50	80.5	30.5	66.5	90.5	40.5	76.5	28.5	14	28	7	20	22	44	20	26	M10X1.5	M8XP1.25	M18X1.5	14	8	33.5
	75,100	90.5	40.5	76.5																		
Ø63	5~50	88	36	84	98	46	84	28.5	14	30	8	20	22	44	20	26	M10X1.5	M10XP1.5	M18X1.5	14	8	33.5
	75,100	98	46																			
Ø80	5~50	109.5	43.5	101.5	119.5	53.5	101.5	35.5	18	38	10	27	28	56	25	32.5	M16X2.0	M12XP1.75	M22X1.5	18	10	43.5
	75,100	119.5	53.5																			
Ø100	5~50	132	53	120	142	63	120	35.5	22	45	13	31	32	64	30	32.5	M20X2.5	M12XP1.75	M26X1.5	22	12	43.5
	75,100	142	63																			

Dimensions-With Air Cushion

Bore size : $\varnothing 20, \varnothing 25$

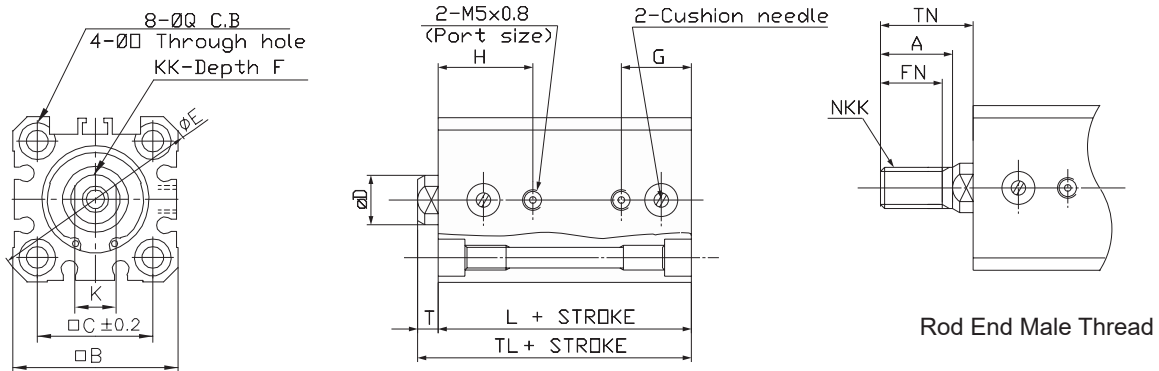

Unit : mm

Bore size	A	□B	□C	ØD	ØE	F	G	H	FN	K	KK	L	NKK	ØO	ØQ	T	TL	TN
Ø20	14	36	25.5	10	47	8	15.5	21	12	M5X0.8	32	M8X1.25	5.5	9 Depth 7	4.5	36.5	18.5	18.5
Ø25	17.5	40	28	12	52	12	17	23	15	M6X1.0	36.5	M10X1.25	5.5	9 Depth 7	5	41.5	22.5	22.5

Bore size : $\varnothing 32, \varnothing 40, \varnothing 50, \varnothing 63, \varnothing 80, \varnothing 100$

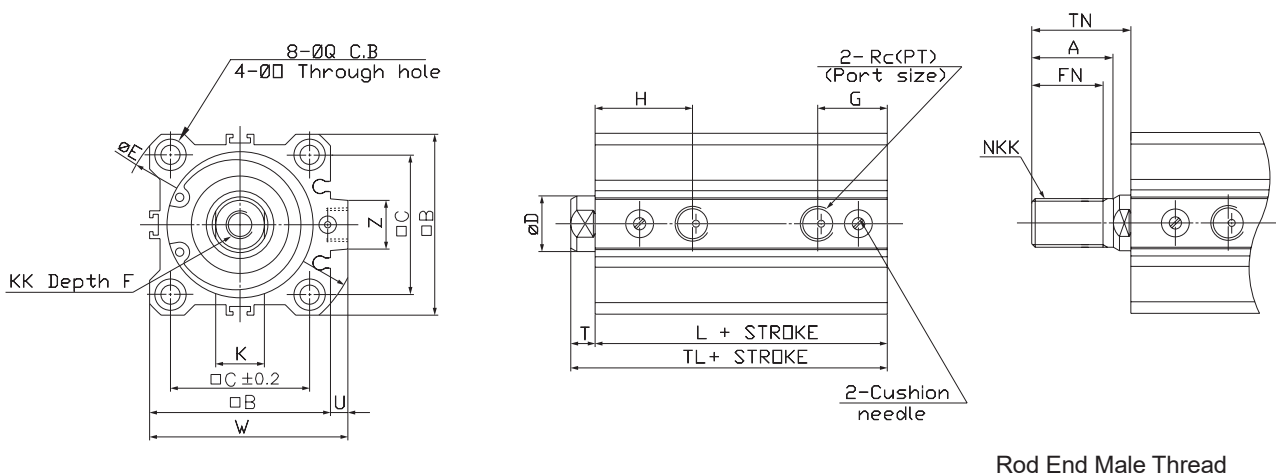

Unit : mm

Bore size	A	□B	□C	ØD	ØE	F	FN	G	H	K	KK	L	NKK	ØO	ØQ	Rc(PT)	T	TL	TN	U	W	Z
Ø32	23.5	45	34	16	60	13	20.5	18.5	23	14	M8X1.25	37	M14X1.5	5.5	9 Depth 7	1/8	7	44	28.5	4.5	49.5	14
Ø40	23.5	52	40	16	69	13	20.5	20	28	14	M8X1.25	44	M14X1.5	5.5	9 Depth 7	1/8	7	51	28.5	5	57	14
Ø50	28.5	64	50	20	86	15	26	28.5	31.5	18	M10X1.5	49.5	M18X1.5	6.8	11 Depth 8	1/4	8	57.5	33.5	7	71	18
Ø63	28.5	77	60	20	103	15	26	31	34	18	M10X1.5	55	M18X1.5	9	14 Depth 10.5	1/4	8	63	33.5	7	84	18
Ø80	35.5	98	77	25	132	21	32.5	35.5	39	22	M16X2.0	63.5	M22X1.5	11	17.5 Depth 13.5	3/8	10	73.5	43.5	6	104	22
Ø100	35.5	117	94	30	156	27	32.5	40	43	27	M20X2.5	76	M26X1.5	11	17.5 Depth 13.5	3/8	12	88	43.5	6.5	123.5	22

Dimensions-Long Stroke Cylinder (AF, ADF)

Rod End-Female Thread (Standard)
($\varnothing 12 \sim \varnothing 20$)

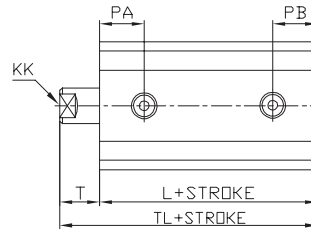
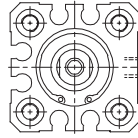

($\varnothing 20 \sim \varnothing 125$)

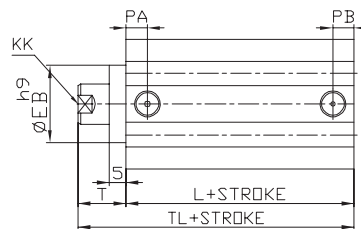
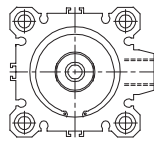

Rod End-Male Thread
($\varnothing 12 \sim \varnothing 20$)

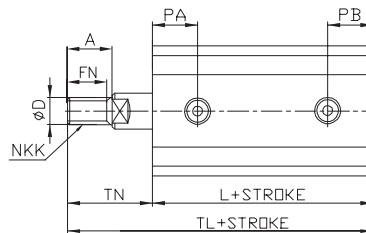
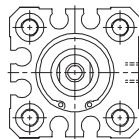

($\varnothing 25 \sim \varnothing 125$)

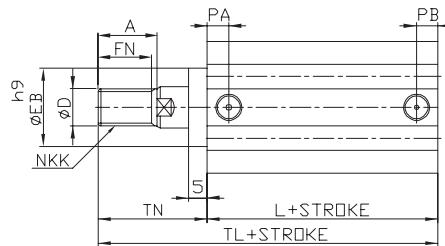
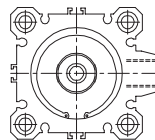

Unit : mm

Bore size	Stroke	A	ØD	ØEB	FN	L	KK	NKK	PA	PB	T	TL	TW	TN
Ø12	35~100	10.5	6	-	9	35	M3X0.5	M5X0.8	10	10	13.5	48.5	59	24
Ø16	35~100	12	8	-	10	38	M4X0.7	M6X1.0	10	10	13.5	51.5	63.5	25.5
Ø20	75~200	14	10	-	12	41	M5X0.8	M8X1.25	10.5	10.5	14.5	55.5	69.5	28.5
Ø25	75~200	17.5	12	17	15	44	M6X1.0	M10X1.25	11	11	15	59	76.5	32.5
Ø32	125~300	23.5	16	22	20.5	45.5	M8X1.25	M14X1.5	12.5	12.5	17	62.5	84	38.5
Ø40	125~300	23.5	16	28	20.5	55	M8X1.25	M14X1.5	14	14	17	72	93.5	38.5
Ø50	125~300	28.5	20	35	26	55.5	M10X1.5	M18X1.5	14	14	18	73.5	99	43.5
Ø63	125~300	28.5	20	35	26	57	M10X1.5	M18X1.5	16.5	16.5	18	75	100.5	43.5
Ø80	125~300	35.5	25	43	32.5	66	M16X2.0	M22X1.5	19	19	20	86	119.5	53.5
Ø100	125~300	35.5	30	59	32.5	75.5	M20X2.5	M26X1.5	23	23	22	97.5	129	53.5
Ø125	5~300	45	35	35	42	83	M22X2.5	M30X1.5	24.5	24.5	16	99	141	58

※ $\varnothing 125$ type and standard type have the same dimensions.
 ※ For dimensions not shown in those figures, refer to the standard type.

Dimensions-Double Acting Double Rod (AFW, ADFW)

Rod End-Female Thread (Standard)

Ø20 ~ Ø25

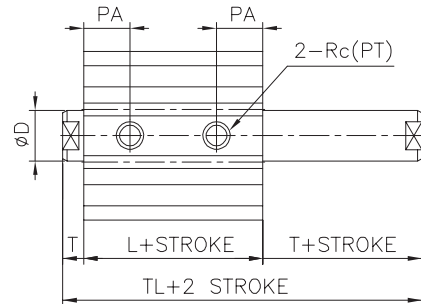
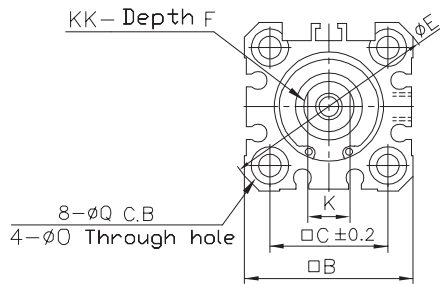

Rod End-Male Thread

Ø20 ~ Ø25

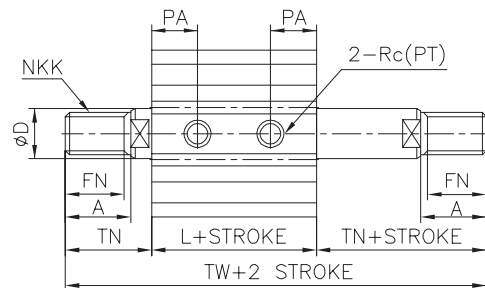
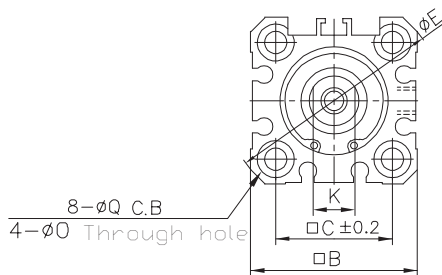

Unit : mm

Bore size	Stroke	Without magnet (AF)			With magnet (ADF)			A	□B	C	□C	ØD	ØE	F	FN	K
		L	TL	TW	L	TL	TW									
Ø20	5-50	26	35	63	38	47	75	14	36	36	25.5	10	47	8	12	8
Ø25	5-50	29	39	74	39	49	84	17.5	40	40	28	12	52	12	15	10

Bore size	K	KK	NKK	ØO	PA	ØQ	Rc(PT)	T	TN
Ø20	8	M5X0.8	M8X1.25	5.5	10.5	9 Depth 7	M5X0.8	4.5	18.5
Ø25	10	M6X1.0	M10X1.25	5.5	11	9 Depth 7	M5X0.8	5	22.5

Both End Tapped (Standard)

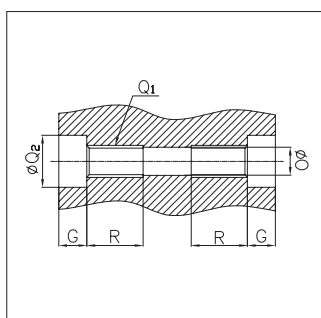

Unit : mm

Bore size	G	Q ₁	ØQ ₂	R
Ø20	7	M6×1.0	9	10
Ø25	7	M6×1.0	9	10

Dimensions-Double Acting Double Rod (AFW, ADFW)

Rod End-Female Thread (Standard)

Ø32 ~ Ø160

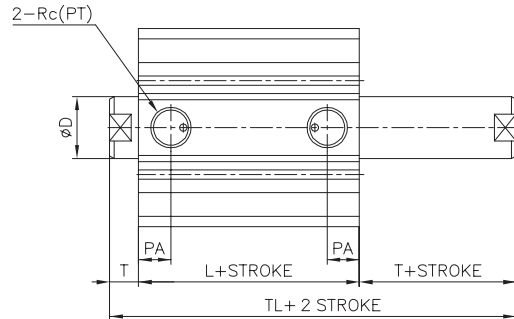
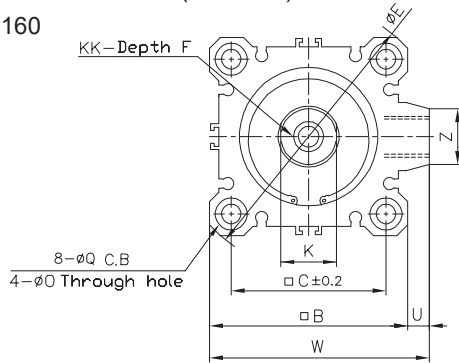

Rod End-Male Thread

Ø32 ~ Ø160

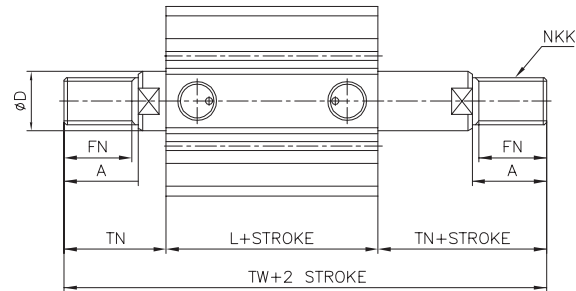
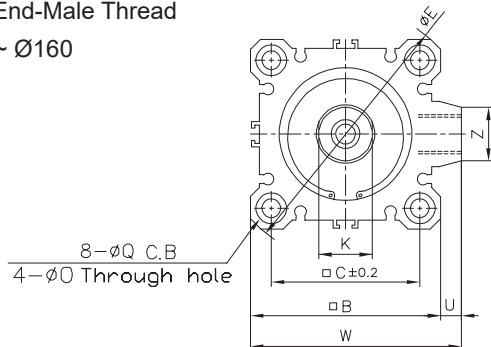

Unit : mm

Bore size	Stroke	Without magnet (AF)			With magnet (ADF)			A	□B	□C	ØD	ØE	F	FN	K	KK	NKK	ØO	PA
		L	TL	TW	L	TL	TW												
Ø32	5~50	30.5	44.5	87.5	40.5	54.5	97.5	23.5	45	34	16	60	13	20.5	14	M8X1.25	M14X1.5	5.5	10.5
	75,100	40.5	54.5	97.5															
Ø40	5~50	40	54	97	50	64	107	23.5	52	40	16	69	13	20.5	14	M8X1.25	M14X1.5	5.5	12
	75,100	50	64	107															
Ø50	5~50	40.5	56.5	107.5	50.5	66.5	117.5	28.5	64	50	20	86	15	26	18	M10X1.5	M18X1.5	6.8	10.5
	75,100	50.5	66.5	117.5															
Ø63	5~50	42	58	109	52	68	119	28.5	77	60	20	103	15	26	18	M10X1.5	M18X1.5	9	15
	75,100	52	68	119															
Ø80	5~50	51	71	138	61	81	148	35.5	98	77	25	132	21	32.5	22	M16X2.0	M22X1.5	11	18
	75,100	61	81	148															
Ø100	5~50	60.5	84.5	147.5	70.5	94.5	157.5	35.5	117	94	30	156	27	32.5	27	M20X2.5	M26X1.5	11	23
	75,100	70.5	94.5	157.5															
Ø125	5~100	83	115	199	83	115	199	45	142	114	35	190	30	42	30	M22X2.5	M30X1.5	12.5	24.5
Ø140	5~100	83	115	199	83	115	199	45	158	128	35	210	30	42	30	M22X2.5	M30X1.5	12.5	24.5
Ø160	5~100	91	125	219	91	125	219	50	178	144	40	238	33	47	36	M24X3.0	M36X1.5	14.5	27.5

Bore size	ØQ	Rc(PT)	T	TN	U	W	Z
Ø32	9 Depth 7	Rc(PT)1/8	7	28.5	4.5	49.5	14
Ø40	9 Depth 7	Rc(PT)1/8	7	28.5	5	57	14
Ø50	11 Depth 8	Rc(PT)1/4	8	33.5	7	71	18
Ø63	14 Depth 10.5	Rc(PT)1/4	8	33.5	7	84	18
Ø80	17.5 Depth 13.5	Rc(PT)3/8	10	43.5	6	104	22
Ø100	17.5 Depth 13.5	Rc(PT)3/8	12	43.5	6.5	123.5	22
Ø125	21.2 Depth 18.4	Rc(PT)3/8	16	58	11	153	32
Ø140	21.2 Depth 18.4	Rc(PT)3/8	16	58	10	168	32
Ø160	24.2 Depth 21.2	Rc(PT)3/8	17	64	10	188	32

Both End Tapped (Standard)

Unit : mm

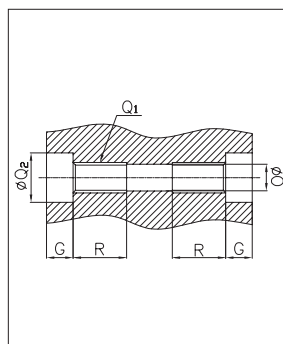

Bore size	G	Q ₁	ØQ ₂	R
Ø32	7	M6X1.0	9	10
Ø40	7	M6X1.0	9	10
Ø50	8	M8X1.25	11	14
Ø63	10.5	M10X1.50	14	18
Ø80	13.5	M12X1.75	17.5	22
Ø100	13.5	M12X1.75	17.5	22
Ø125	18.4	M14X2.0	21.2	25
Ø140	18.4	M14X2.0	21.2	25
Ø160	21.2	M16X2.0	24.2	28

Single Rod Multi-Step Stroke Cylinder (TS)

By integrating two cylinders in series enable back and forth stroke and two-steps control for a doubled output.

Ordering notation: A Stroke + Total Stroke

Ex) 20 + 30 (A Side = 20, B Side = 10)

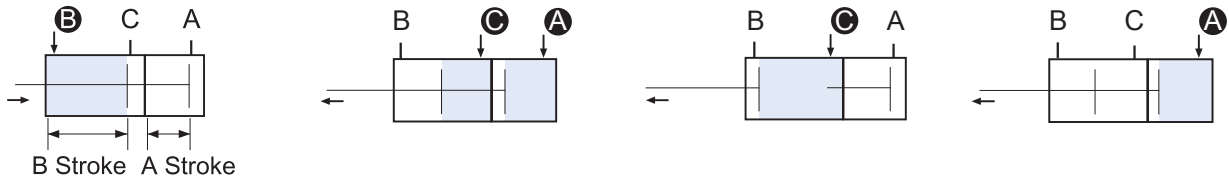

When B port is supplied with air pressure, A and B strokes reverse.

When both A and C ports are supplied with air pressure, forward output is doubled.

When C port is supplied with air pressure, rod and B Stroke move forward.

When A port is supplied with air pressure, rod and A Stroke move forward.

Dimensions-Single Rod Multi-Step Stroke Cylinder (TS)

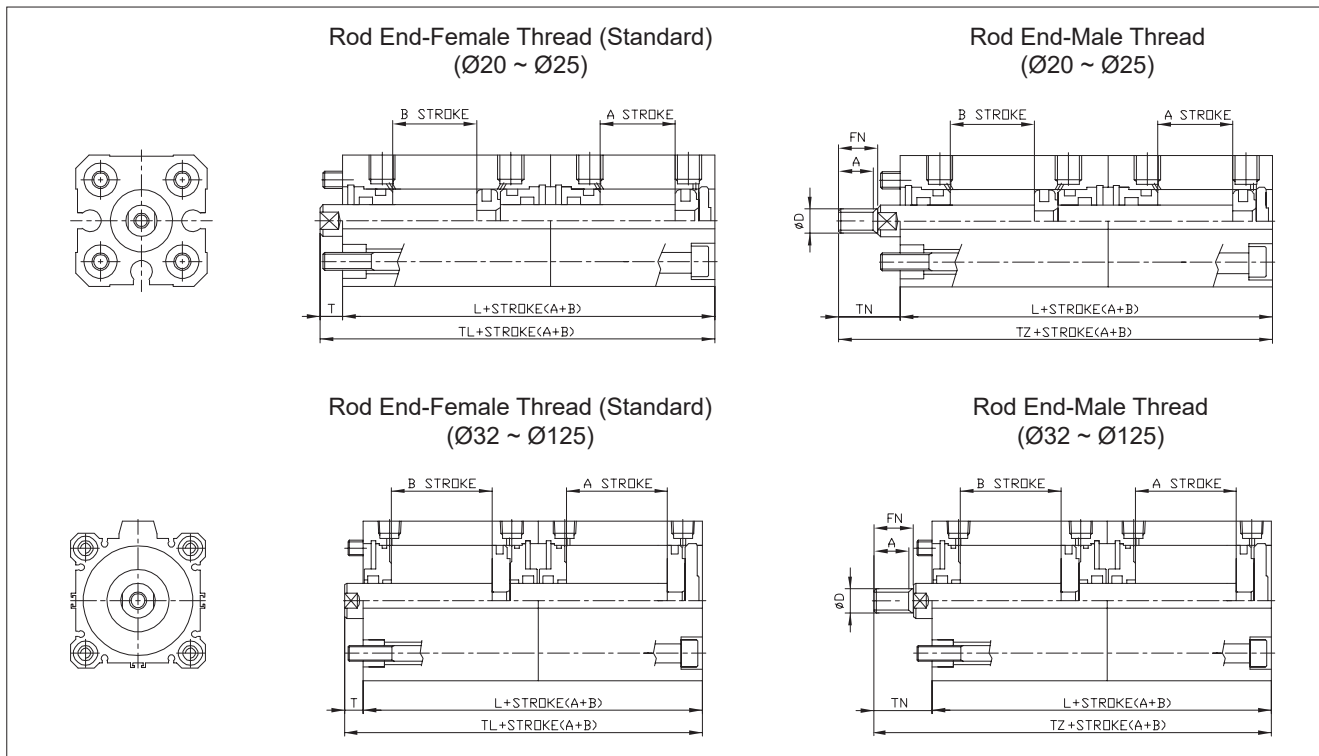

Unit : mm

Bore size	Stroke	Without magnet (AF)			With magnet (ADF)			A	ØD	FN	T	TN
		L	TL	TZ	L	TL	TZ					
Ø20	5~100	45.5	50	64	69.5	74	88	14	10	12	4.5	18.5
Ø25	5~100	51.5	56.5	74	71.5	76.5	94	17.5	12	15	5	22.5
Ø32	5~50	53.5	60.5	82	73.5	80.5	102	23.5	16	20.5	7	28.5
	75,100	73.5	80.5	102								
Ø40	5~50	69.5	76.5	98	89.5	96.5	118	23.5	16	20.5	7	28.5
	75,100	89.5	96.5	118								
Ø50	5~50	71	79	104.5	91	99	124.5	28.5	20	26	8	33.5
	75,100	91	99	124.5								
Ø63	5~50	78	86	111.5	98	106	131.5	28.5	20	26	8	33.5
	75,100	98	106	131.5								
Ø80	5~50	94.5	104.5	138	114.5	124.5	158	35.5	25	32.5	10	43.5
	75,100	114.5	124.5	158								
Ø100	5~50	113.5	125.5	157	133.5	145.5	177	35.5	30	32.5	12	43.5
	75,100	133.5	145.5	177								
Ø125	5~100	166	182	224	166	182	224	45	35	42	16	58

※ For dimensions not shown in above figures, refer to the standard type.

Multi-Step Stroke Cylinder (TW)

Head side assembly. By integrating two cylinders enable back and forth stroke and three steps control.

Ordering notation: A Stroke + B Stroke

Example) 20 + 30 (A Side = 20, B Side = 30)

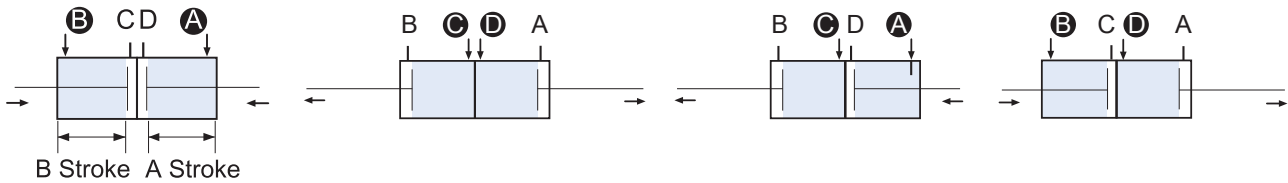

When A and B ports are supplied with air pressure, A and B strokes reverse.

When C and D ports are supplied with air pressure, A and B strokes move forward.

When A and C ports are supplied with air pressure, B stroke move forward.

When B and D ports are supplied with air pressure, A stroke move forward.

Dimensions-Multi-Step Stroke Cylinder (TW)

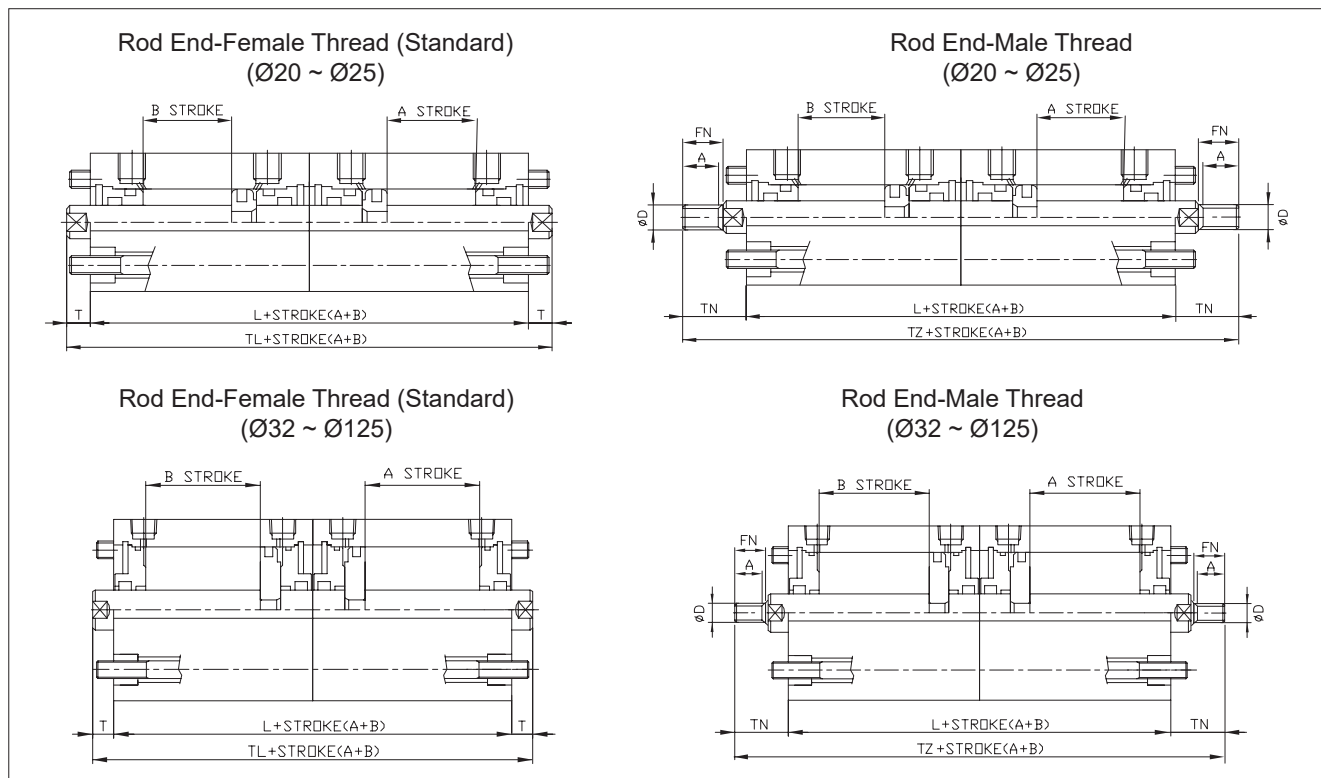

Unit : mm

Bore size	Stroke	Without magnet (AF)			With magnet (ADF)			A	ØD	FN	T	TN
		L	TL	TZ	L	TL	TZ					
Ø20	5~100	45.5	54.5	82.5	69.5	78.5	106.5	14	10	12	4.5	18.5
Ø25	5~100	51.5	61.5	96.5	71.5	81.5	116.5	17.5	12	15	5	22.5
Ø32	5~50	53.5	67.5	110.5	73.5	87.5	130.5	23.5	16	20.5	7	28.5
	75,100	73.5	87.5	130.5								
Ø40	5~50	69.5	83.5	126.5	89.5	103.5	146.5	23.5	16	20.5	7	28.5
	75,100	89.5	103.5	146.5								
Ø50	5~50	71	87	138	91	107	158	28.5	20	26	8	33.5
	75,100	91	107	158								
Ø63	5~50	78	94	145	98	114	165	28.5	20	26	8	33.5
	75,100	98	114	165								
Ø80	5~50	94.5	114.5	181.5	114.5	134.5	201.5	35.5	25	32.5	10	43.5
	75,100	114.5	134.5	201.5								
Ø100	5~50	113.5	137.5	200.5	133.5	157.5	220.5	35.5	30	32.5	12	43.5
	75,100	133.5	157.5	220.5								
Ø125	5~100	166	198	282	166	198	282	45	35	42	16	58

* For dimensions not shown in these figures, refer to the standard type.

Forward Stroke Adjustable Cylinder (ASJ, BSJ)

To adjust the entire forward stroke from 0mm to 20mm an adjustment mechanism is attached to the head side.

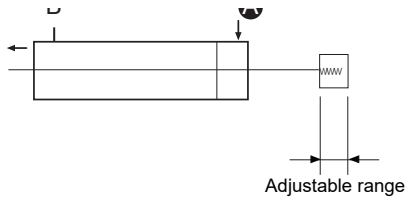

ASJ : 0~10mm adjustment
BSJ : 0~20mm adjustment

Dimensions-Forward Stroke Adjustable (ASJ, BSJ)

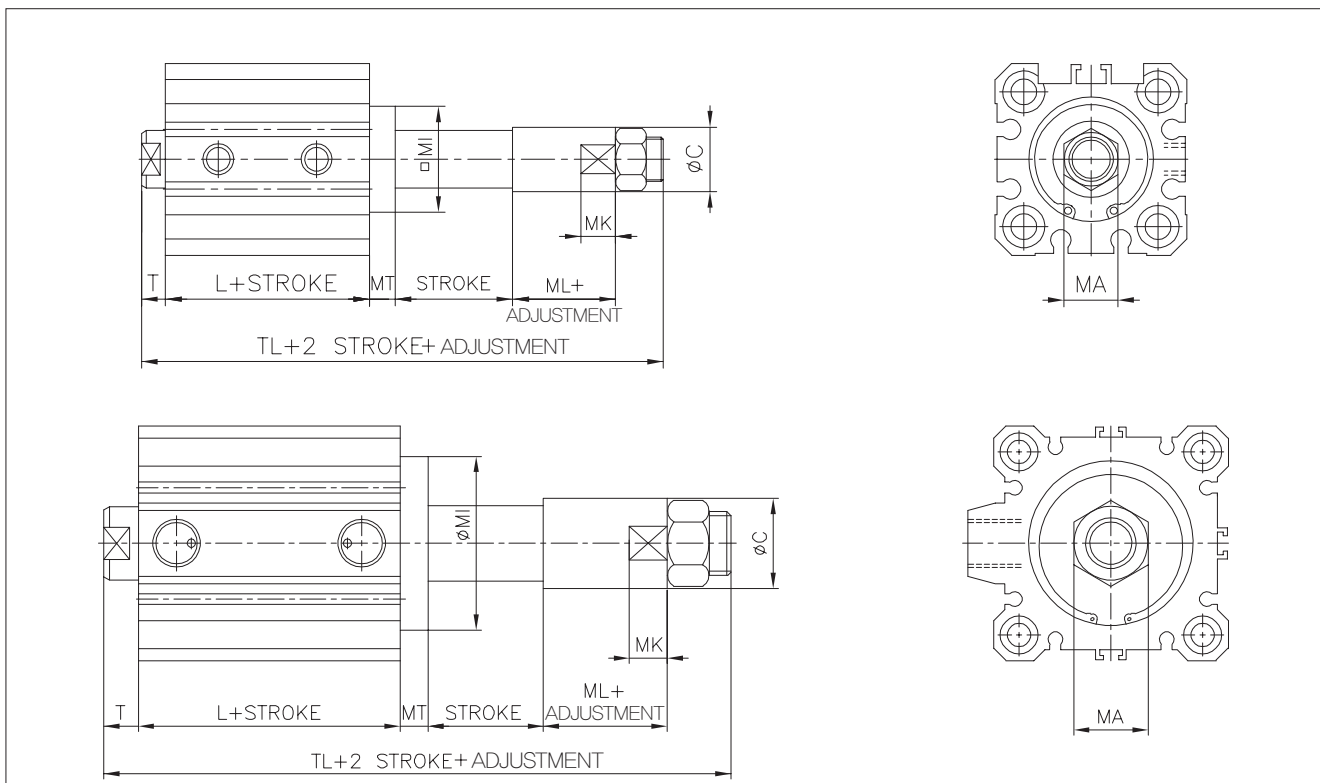

Unit : mm

Bore size	ØC	L	MI	MT	MK	ML	MT	T	TL
Ø20	20	26	□36	8	10	12.5	13	4.5	61
Ø25	20	29	□36	8	10	12.5	17	5	64.5
Ø32	27	30.5	Ø38	6	14	16	22	7	72.5
Ø40	27	40	Ø46	6	14	16	22	7	82
Ø50	35	40.5	Ø57	8	16	20	27	8	91.5
Ø63	35	42	Ø68	10	16	20	27	8	95
Ø80	48	51	Ø90	12	20	28	32	10	119
Ø100	48	60.5	Ø110	14	20	28	41	12	134.5
Ø125	60	83	-	-	15	35	46	16	157

※ For dimensions not shown in these figures, refer to the AF series standard type.

Dimensions-Anti-Lateral Load (E) - AF, ADF

Rod End-Female Thread (Standard)
($\varnothing 12 \sim \varnothing 20$)

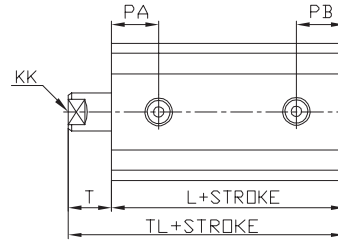
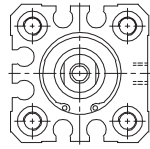

($\varnothing 20 \sim \varnothing 125$)

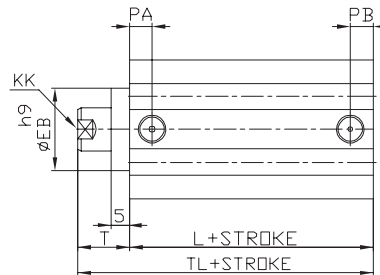
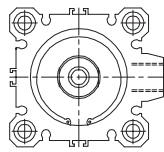

Rod End-Male Thread
($\varnothing 12 \sim \varnothing 20$)

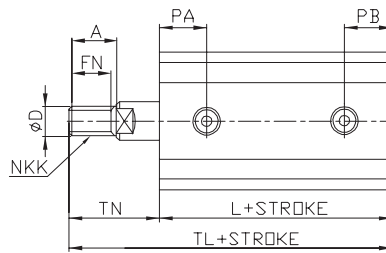
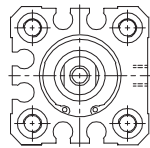

($\varnothing 25 \sim \varnothing 125$)

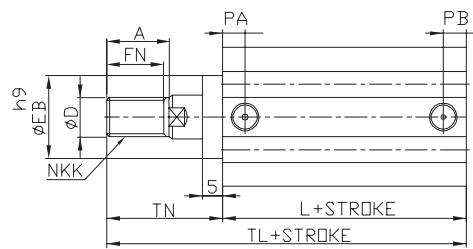
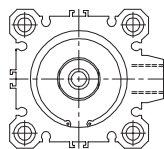

Unit : mm

Bore size	Stroke	A	ØD	ØEB	FN	ØEB	L	KK	NKK	PA	PB	T	TL	TN
Ø12	5~30	10.5	6	-	9	38	M3X0.5	M5X0.8	10	10	13.5	51.5	62	24
Ø16	5~30	12	8	-	10	40.5	M4X0.7	M6X1.0	10	10	13.5	54	66	25.5
Ø20	5~50	14	10	-	12	41.5	M5X0.8	M8X1.25	10.5	10.5	14.5	56	70	28.5
Ø25	5~50	17.5	12	17	15	42.5	M6X1.0	M10X1.25	11	11	15	57.5	75	32.5
Ø32	5~100	23.5	16	22	20.5	43	M8X1.25	M14X1.5	12.5	12.5	17	60	81.5	38.5
Ø40	5~100	23.5	16	28	20.5	49.5	M8X1.25	M14X1.5	14	14	17	66.5	88	38.5
Ø50	5~100	28.5	20	35	26	50.5	M10X1.5	M18X1.5	14	14	18	68.5	94	43.5
Ø63	5~100	28.5	20	35	26	56	M10X1.5	M18X1.5	16.5	16.5	18	74	99.5	43.5
Ø80	5~100	35.5	25	43	32.5	63.5	M16X2.0	M22X1.5	19	19	20	83.5	117	53.5
Ø100	5~100	35.5	30	59	32.5	73	M20X2.5	M26X1.5	23	23	22	95	126.5	53.5
Ø125	5~100	45	35	35	42	83	M22X2.5	M30X1.5	24.5	24.5	16	99	141	58

※ $\varnothing 125$ type and standard type have the same dimensions.
 ※ For dimensions not shown in those figures, refer to the standard type.

Dimensions-Power Scraper Attached Cylinder (MS)

Rod End-Female Thread (Standard)

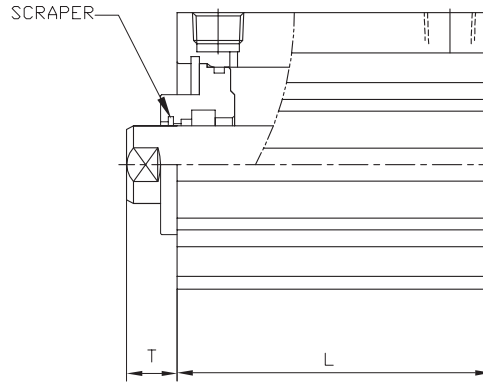
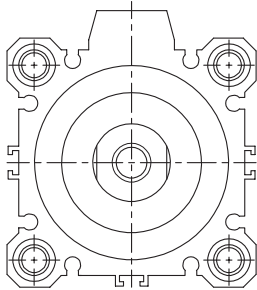

Rod End-Male Thread - (AF, ADF)

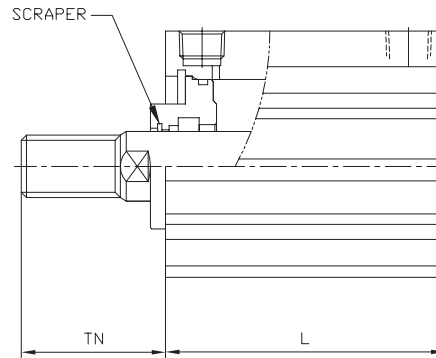
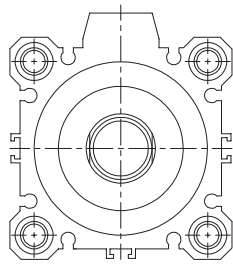

Unit : mm

Bore size	Stroke	Without magnet (AF)	With magnet (ADF)	T	TN
		L			
Ø32	5-50	23	33	7	28.5
	75,100	33			
Ø40	5-50	29.5	39.5	12	33.5
	75,100	39.5			
Ø50	5-50	30.5	40.5	13	38.5
	75,100	40.5			
Ø63	5-50	36	46	13	38.5
	75,100	46			
Ø80	5-50	43.5	53.5	15	48.5
	75,100	53.5			

※ For dimensions not shown in those figures, refer to the standard type.

Dimensions-Accessory

Unit : mm

Single Knuckle Joint

Material: Carbon Steel

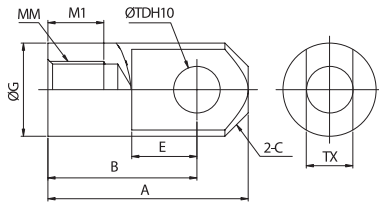

Part no.	Bore size	A	B	C	E	ØG	MM	MI	ØTDH10	TX
I(CP)12	Ø12	21.5	16	2.5	7	12	M5X0.8	6	5 ^{+0.048} ₀	5 ^{-0.2} _{-0.4}
I(CP)16	Ø16	32	25	3	14	14	M6X1.0	8	5 ^{+0.048} ₀	6.4 ^{-0.2} _{-0.4}
I(CP)20	Ø20	34	25	4	11.5	18	M8X1.25	8.5	8 ^{+0.058} ₀	8 ^{-0.2} _{-0.4}
I(CP)25	Ø25	41	30	5	14	23	M10X1.25	10.5	10 ^{+0.058} ₀	10 ^{-0.2} _{-0.5}
I(CP)32,40	Ø32,40	42	30	6	14	29	M14X1.5	14	10 ^{+0.058} ₀	18 ^{-0.3} _{-0.5}
I(CP)50,63	Ø50,63	56	40	6.5	20	36	M18X1.5	18	14 ^{+0.070} ₀	22 ^{-0.3} _{-0.5}
I(CP)80	Ø80	71	50	8	27	38	M22X1.5	21	18 ^{+0.070} ₀	28 ^{-0.3} _{-0.5}
I(CP)100	Ø100	79	55	10	31	44	M26X1.5	21	22 ^{+0.084} ₀	32 ^{-0.3} _{-0.5}

Double Knuckle Joint

Ø12~Ø16

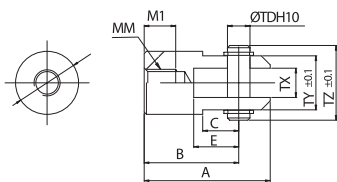

Material: Carbon Steel

Ø20, Ø25

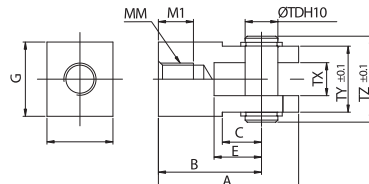

Material: Carbon Steel

Ø32~Ø100

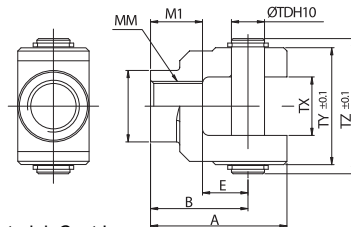

Material: Cast Iron

Unit : mm

Part no.	Bore size	A	B	C	E	ØG	MM	MI	ØTDH10	TX	TY	TZ
Y(CP)12	Ø12	21.5	16	6	7	Ø12	M5X0.8	6	5 ^{+0.048} ₀	5 ^{-0.4} _{-0.2}	10	14.6
Y(CP)16	Ø16	28	21	8	10	Ø16	M6X1.0	7	5 ^{+0.048} ₀	6.4 ^{-0.4} _{-0.2}	12	16.6
Y(CP)20	Ø20	34	25	9.5	11.5	□18	M8X1.25	8.5	8 ^{+0.058} ₀	8 ^{-0.4} _{-0.2}	16	21
Y(CP)25	Ø25	41	30	14	14	□22	M10X1.25	10.5	10 ^{+0.058} ₀	10 ^{-0.4} _{-0.2}	20	25.6
Y(CP)32,40	Ø32,40	42	30	-	14	Ø22	M14X1.5	16	10 ^{+0.058} ₀	18 ^{-0.5} _{-0.3}	36	41.6
Y(CP)50,63	Ø50,63	56	40	-	20	Ø28	M18X1.5	20	14 ^{+0.070} ₀	22 ^{-0.5} _{-0.3}	44	50.6
Y(CP)80	Ø80	71	50	-	27	Ø38	M22X1.5	23	18 ^{+0.070} ₀	28 ^{-0.5} _{-0.3}	56	64
Y(CP)100	Ø100	79	55	-	31	Ø44	M26X1.5	24	22 ^{+0.084} ₀	32 ^{-0.5} _{-0.3}	64	72

Knuckle Joint Pin / Clevis Pin

Material: Carbon Steel

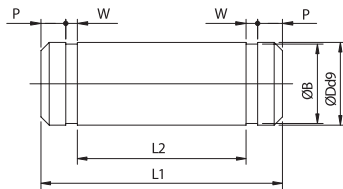

Unit : mm

Part no.	Bore size	ØDd9	L1	L2	P	W	B	Retaining ring
CJP(CP)12	Ø12	5 ^{-0.03} _{-0.06}	14.6	10.2	1.5	0.7	6	Type C 5 for axis
CJP(CP)16	Ø16	5 ^{-0.03} _{-0.06}	16.6	12.2	1.5	0.7	8	Type C 5 for axis
CJP(CP)20	Ø20	8 ^{-0.04} _{-0.076}	21	16.2	1.5	0.9	8.5	Type C 8 for axis
CJP(CP)25	Ø25	10 ^{-0.04} _{-0.076}	25.6	20.2	1.55	1.15	10.5	Type C 10 for axis
CJP(CP)32,40	Ø32,40	10 ^{-0.04} _{-0.076}	41.6	36.2	1.55	1.15	14	Type C 10 for axis
CJP(CP)50,63	Ø50,63	14 ^{-0.05} _{-0.076}	50.6	44.2	2.05	1.15	18	Type C 14 for axis
CJP(CP)80	Ø80	18 ^{-0.05} _{-0.093}	64	56.2	2.55	1.35	21	Type C 18 for axis
CJP(CP)100	Ø100	22 ^{-0.065} _{-0.117}	72	64.2	2.55	1.35	21	Type C 22 for axis

Rod End Nut

Material: Carbon Steel

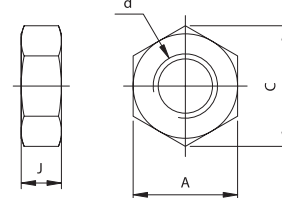

Unit : mm

Part no.	Bore size	d	J	A	C
RN(CP)12	Ø12	M5X0.8	4	8	9.2
RN(CP)16	Ø16	M6X1.0	5	10	11.5
RN(CP)20	Ø20	M8X1.25	5	13	15
RN(CP)25	Ø25	M10X1.25	6	17	19.6
RN(CP)32,40	Ø32,40	M14X1.5	8	22	25.4
RN(CP)50,63	Ø50,63	M18X1.5	11	27	31.2
RN(CP)80	Ø80	M22X1.5	13	32	37.0
RN(CP)100	Ø100	M26X1.5	16	41	47.3