

ACL series



ACL-B 140-S125

Features

- Excellent durability and performance.
- Large pneumatic cylinders provide various mounting options.
- The cover, tube and piston are made of lightweight aluminum. (Aluminum type)
- Significantly improved cushion performance (aluminum type).
- Auto switch can be mounted up to Ø200 with the built-in magnet (aluminum type).

Symbol

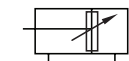

Double Acting / Single Rod

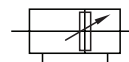

Double Acting / Double Rod

How to Order

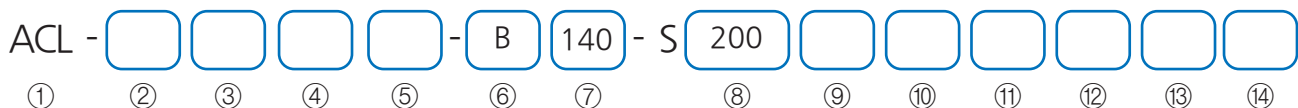

① Series

ACL	Double acting single rod large cylinder
ACLW	Double acting double rod large cylinder

② Lubrication

N	Non lubricated (Standard)
L	Low hydraulic pressure (≤9.9kgf/cm ²)
G	Low hydraulic pressure (≤24.5kgf/cm ²)
Q	Low friction

③ Magnet

Nil	Without built-in magnet
H	Built-in magnet

* Iron tube is not a built-in magnet.

④ Tube material

Nil	AL
F	Steel

* Stainless steel tube is also available. Please inquire separately.

⑤ Cover material

	Ø125~Ø200	Ø250~Ø300
Nil	AL(Standard)	Steel(Standard)
FC	Steel	-

* SUS and copper alloy covers are also available. Please inquire separately.

⑥ Mounting style

B	Standard	CB	Double Clevis
LB	Foot	TC	Center Trunnion
FA	Rod Side Flange	TA	Rod Side Trunnion
FB	Head Side Flange	TB	Head Side Trunnion
CA	Single Clevis		

⑦ Bore size

125	140	150	160
Ø125	Ø140	Ø150	Ø160
180	200	250	300
Ø180	Ø200	Ø250	Ø300

* Refer to page [1]-133, for specifications about custom-made rod ends.

⑧ Cylinder stroke

Bore size	Standard stroke	Max. stroke
Ø125	25, 50, 75, 100, 125, 150, 175, 200, 250, 300, 350, 400, 450, 500	2950
Ø140	25, 50, 75, 100, 125, 150, 175, 200, 250, 300	
Ø150	25, 50, 75, 100, 125, 150, 175, 200, 250, 300, 350, 400, 450, 500	
Ø160	25, 50, 75, 100, 125, 150, 175, 200, 250, 300	
Ø180	25, 50, 75, 100, 125, 150, 175, 200, 250, 300	
Ø200	50, 100, 150, 200, 250, 300	-
Ø250	50, 100, 150, 200, 250, 300	
Ø300	-	

* Other intermediate strokes available on request. ⑬ Special Order

⑨ Bellows

	Material	Max. ambient temperature
Nil	Without bellows	
J	Nylon Tarpaulin	60 °C
K	Neoprene Cloth	110 °C

⑩ Rod end attachment

Nil	Rod end nut(Standard) : 1pc
I	Single knuckle joint
Y	Double knuckle joint

⑪ Auto switch

Reed A/S	Model	Solid state A/S	Model
A54	D-A54K	F59	D-F59K
A56	D-A56K	F5P	D-F5PK
A64	D-A64K	J59	D-J59K
A90(V)	D-A90(V)K	J51	D-J51K
A93(V)	D-A93(V)K	F9N	D-F9N(V)K
A96(V)	D-A96(V)K	F9P	D-F9P(V)K
		F9B	D-F9B(V)K

* Only for auto switch attached type.
* Refer to Auto Switch Catalogue for more information.

⑫ Number of auto switches

Nil	2 pcs
1	1 pc
N	N pcs (N: 3, 4, 5...)

* Only for auto switch attached type.

Nil	None
TS	Multi-step stroke cylinder (Single rod)
TW	Multi-step stroke cylinder (Double rod)
TD	Tandem cylinder
ASJ	Stroke adjustable type (in forward direction within 25mm)
BSJ	Stroke adjustable type (in forward direction within 50mm)
SV	Heat resistant cylinder (-20 °C~150 °C)
LT	Cold resistant cylinder (-40 °C~70 °C)
SS	Stainless steel piston rod

⑬ Low friction direction

R	Side at pressure when pressurized on rod side
H	Side at pressure when pressurized on head side

* Applies to low friction type.

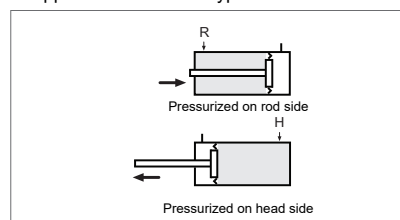

Specifications

Type	Lubricated, Non-lubricated	Low hydraulic pressure
Fluid	Air	Hydraulic fluid
Proof pressure	15.7kgf/cm ² (1.6MPa)	
Max. operating pressure	9.9kgf/cm ² (1.0MPa)	Low pressure L type:9.9kgf/cm ² (1.0MPa) Low pressure G type:24.5kgf/cm ² (2.5MPa)
Min. operating pressure	0.5kgf/cm ² (0.05MPa)	0.6kgf/cm ² (0.06MPa)
Ambient & fluid temperature	5 ~ 60°C	
Operating piston speed	50 ~ 500mm/sec	0.5 ~ 200mm/sec
Cushion	With cushion	Without cushion
Tolerance of thread	KS class 2	
Tolerance of stroke	~250 ST : $^{+1.0}_0$ ~1000 ST : $^{+1.4}_0$ ~1500 ST : $^{+1.8}_0$ ~2000 ST : $^{+2.2}_0$ ~2400 ST : $^{+2.6}_0$	

Accessory

Type		Double acting single rod						
Mounting style		Standard	Foot	Rod side flange	Head side flange	Single clevis	Double clevis	Center trunnion
Standard mounting	Rod end nut	•	•	•	•	•	•	•
	Clevis pin	-	-	-	-	-	•	-
Option	Single knuckle joint	•	•	•	•	•	•	•
	Double knuckle joint	•	•	•	•	•	•	•
	Bellows	•	•	•	•	•	•	•

* For double clevis and double knuckle joint, pin and snap ring are included.

Mounting Style

Mounting style	Bore size	Ø125	Ø140	Ø150	Ø160	Ø180	Ø200	Ø250	Ø300
	Foot		LB125	LB140	LB150	LB160	LB180	LB200	LB250
Flange		FA/FB125	FA/FB140	FA/FB150	FA/FB160	FA/FB180	FA/FB200	FA/FB250	FA/FB300
Single clevis (with pin)		CA125	CA140	CA150	CA160	CA180	CA200	CA250	CA300
Double clevis (with pin)		CB125	CB140	CB150	CB160	CB180	CB200	CB250	CB300

* For foot type mounting, 2 pieces in one set.

Rod End Attachment

Rod end attachment	Bore size	Ø125	Ø140	Ø150, Ø160	Ø180	Ø200	Ø250	Ø300
	Single knuckle joint		I125	I140	I150/160	I180	I200	I250
Double knuckle joint		Y125	Y140	Y150/160	Y180	Y200	Y250	Y300

Mass

Unit: kg

Bore size (mm)		Aluminium tube							
		Double acting single rod				Double acting double rod			
		Ø125	Ø140	Ø150	Ø160	Ø125	Ø140	Ø150	Ø160
Basic mass	Standard	5.38	6.76	8.82	11.78	5.98	7.38	9.49	12.67
	Foot	7.18	8.92	11.58	14.70	7.78	9.54	12.25	15.59
	Flange	8.32	12.40	14.96	18.80	8.92	13.02	15.63	19.69
	Single clevis	8.60	11.42	14.40	17.76	-	-	-	-
	Double clevis (with pin)	8.88	11.74	15.10	18.28	-	-	-	-
	Trunnion	9.51	12.49	15.77	19.18	10.11	13.11	16.44	20.07
Additional mass for each 100mm stroke		1.68	1.68	2.16	2.20	2.37	2.44	3.05	3.11
Accessory	Single knuckle joint	1.04	1.26	1.63	1.63	-	-	-	-
	Double knuckle joint (with pin)	1.37	1.88	2.43	2.43	-	-	-	-
	Rod end nut	0.16	0.16	0.26	0.26	-	-	-	-

Unit: kg

Bore size (mm)		Steel tube													
		Double acting single rod						Double acting double rod							
		Ø125	Ø140	Ø160	Ø180	Ø200	Ø250	Ø300	Ø125	Ø140	Ø160	Ø180	Ø200	Ø250	Ø300
Basic mass	Standard	15.20	18.38	25.24	34.16	42.66	79.78	115.94	16.85	20.03	27.12	36.90	45.79	85.36	122.39
	Foot	16.83	20.90	28.04	38.36	47.54	89.28	133.22	18.48	22.55	29.92	41.10	50.67	94.86	139.67
	Rod side flange	17.88	23.38	31.63	43.99	54.57	101.62	146.14	-	-	-	-	-	-	-
	Head side flange	17.88	23.38	31.63	43.99	54.57	101.62	146.14	-	-	-	-	-	-	-
	Single clevis	18.27	22.67	30.73	42.55	52.56	98.17	149.22	-	-	-	-	-	-	-
	Double clevis (with pin)	18.73	23.42	34.58	44.23	54.59	101.36	154.96	-	-	-	-	-	-	-
	Trunnion	19.33	24.11	32.64	44.78	56.65	107.62	156.37	20.98	25.76	34.52	47.52	59.78	113.20	162.82
Additional mass for each 100mm stroke		2.66	3.01	3.58	4.95	5.75	9.08	12.15	3.46	3.81	4.57	6.20	7.29	11.30	15.17
Accessory	Single knuckle joint	0.91	1.16	1.56	3.07	2.90	5.38	10.82	-	-	-	-	-	-	-
	Double knuckle joint (with pin)	1.37	1.81	2.48	4.74	4.59	9.22	17.17	-	-	-	-	-	-	-
	Rod end nut	0.16	0.16	0.2	0.32	0.85	1.26	1.43	-	-	-	-	-	-	-

Calculation:

- Double acting single rod (Aluminium tube)
Ex) ACL-LB160-S500
Basic mass: 14.70(FootØ160) / Additional mass: 2.20/100 / Cylinder stroke: 500mm
 $14.70 + 2.20/100 \times 500 = 25.70\text{kg}$
- Double acting double rod (Aluminium tube)
Ex) ACLW-LB125-S500
Basic mass: 7.78(FootØ125) / Additional mass: 2.37/100 / Cylinder stroke: 500mm
 $7.78 + 2.37/100 \times 500 = 19.63\text{kg}$

Structure

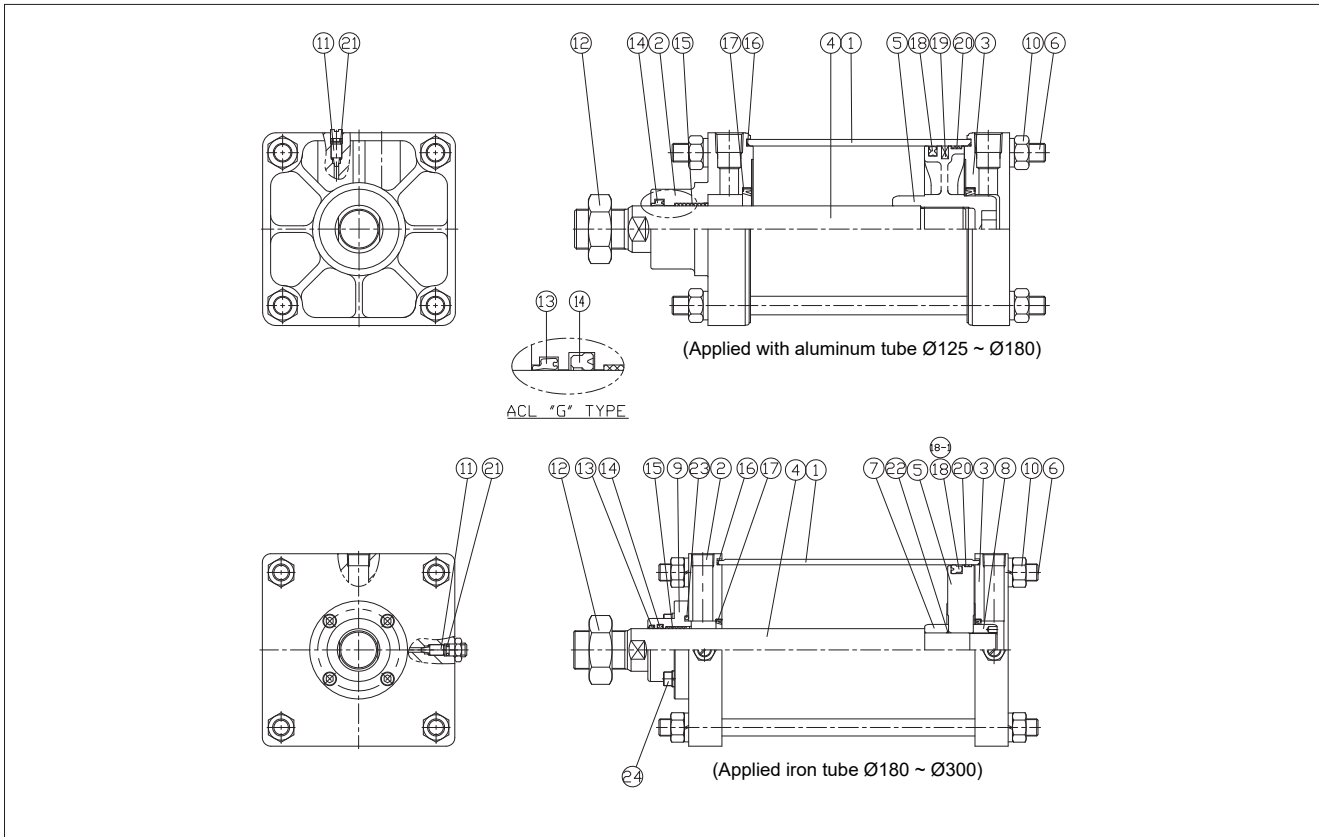

No.	Parts	Material	Remark
1	Tube	AL	Ø125~300
		STKM13C	Ø180~Ø300
2	Rod Cover	ALDC12	Ø125~Ø160
		AC4C	Ø180~Ø200
		SS400	Ø180~Ø300
3	Head Cover	ALDC12	Ø125~160
		AC4C	Ø180~Ø200
4	Rod	SS400	Ø180~Ø300
		SM45C	-

No.	Parts	Material	Remark
5	Piston	AL	Ø125~Ø200
		SS400	Ø250~Ø300
6	Tie Rod	SM20C	-
7	Cushion Ring	SM45C	Ø180~Ø300
8	Cushion Nut	SM45C	Ø180~Ø300
9	Guide Bush	SM20C	Ø180~Ø300
10	Tie Rod Nut	SM20C	-
11	Cushion Needle	C3604	-
12	Rod Nut	SM45C	-
24	Wrench bolt	SM45C	-

No.	Parts	Material	Bore size								Remark
			125Ø	140	150	160	180	200	250	300	
13	Dust seal	N.B.R	-	SDR-35	SDR-40	SDR-40	SDR-45	SDR-50	SDR-60	SDR-70	
14	Rod Packing	N.B.R	ORA-35	SKY-35	SKY-40	SKY-40	SKY-45	SKY-50	SKY-60	SKY-70	
15	DU Bush	SPCC	DUB3525	DUB3525	DUB4025	DUB4025	DUB4525	DUB5030	DUB6040	DUB6040	
16	Tube O-Ring	N.B.R	S125	S140	S150	S160	S180	S200	S250	S300	
17	Cushion Packing	N.B.R	PCS-50	50x 60x 6.2/7.8	50x 60x 6.2/7.8	50x 60x 6.2/7.8	50x 60x 6.2/7.8/PCS-60	PCS-60	PCS-75	PCS-80	
18	Piston Packing	N.B.R	OPA-125	OPA-140	OPA-150	OPA-160	PSD-180	PSD-200	PSD-250	PSD-300	
18-1	Piston Packing (Q)	N.B.R	GLY-110	GLY-125	GLY-135	GLY-145	GLY-165	GLY-180	SKY-230	SKY-280	Low friction
19	Magnet		Ø123x5	Ø138x5	Ø148x5	Ø158x5	Ø178x5	Ø198x5	Ø248x5	Ø298x5	
20	Wearing	PTFE	8x2t	8x2t	8x2t	8x2t	8x2t	8x2t	8x2t	8x2t	
21	Needle O-Ring	NBR	S10	S10	S10	S10	S10	S10	S10	S10	
22	Rod O-Ring	NBR	-	-	-	-	S35	S40	S48	S50	
23	Bush O-Ring	NBR	-	-	-	-	AP63	AP67	AP80	AP85	

Dimensions-Standard (B)

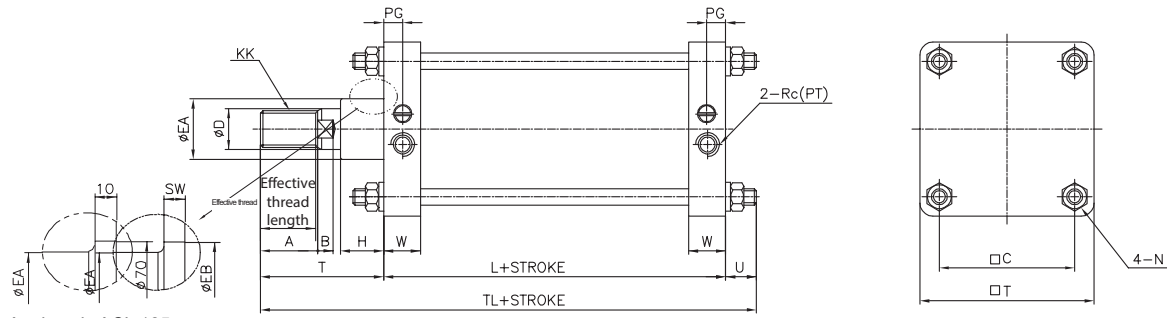

Apply only ACL 125, Ø180, Ø200

(Applied with aluminum tube Ø125 ~ Ø200)

Effective thread

(Applied iron tube Ø180 ~ Ø300)

Unit : mm

Bore size	Effective thread length	A	B	□C	ØD	ØEA	ØEB	H	KK	L	N	PG	Rc(PT)	SW
Ø125	47	50	15	115	35	55	-	43	M30X1.5	98	M14X1.5	16	1/2	-
Ø140	47	50	15	128	35	59	61	42	M30X1.5	98	M14X1.5	16	1/2	8
Ø150	53	56	17	132	40	59	61	43	M36X1.5	106	M16X1.5	17.5	3/4	8
Ø160	53	56	17	144	40	59	61	43	M36X1.5	106	M16X1.5	17	3/4	8
Ø180	60	63	20	162	45	70	115(85)	48	M40X1.5	111	M18X1.5	17	3/4	17
Ø200	60	63	20	182	50	74(70)	115(85)	48	M45X1.5	111	M20X1.5	16.5	3/4	17(8)
Ø250	67	71	25	225	60	96	140	60	M56X2.0	141	M24X1.5	22	1	20
Ø300	76	80	30	270	70	96	140	60	M64X2.0	146	M30X1.5	22	1	20

Bore size	□T	T	TL	U	W
Ø125	145	110	229	21	32
Ø140	161	110	229	(21)	32
Ø150	170	120	249	(23)	36
Ø160	184	120	249	(23)	38
Ø180	204	135	272	(26)	39
Ø200	226	135	276	(30)	39
Ø250	277	160	335	(34)	49
Ø300	330	175	362.5	(41.5)	49

※ ØEA, ØEB, SW () dimensions are for aluminum cover.

Dimensions-Foot (LB)

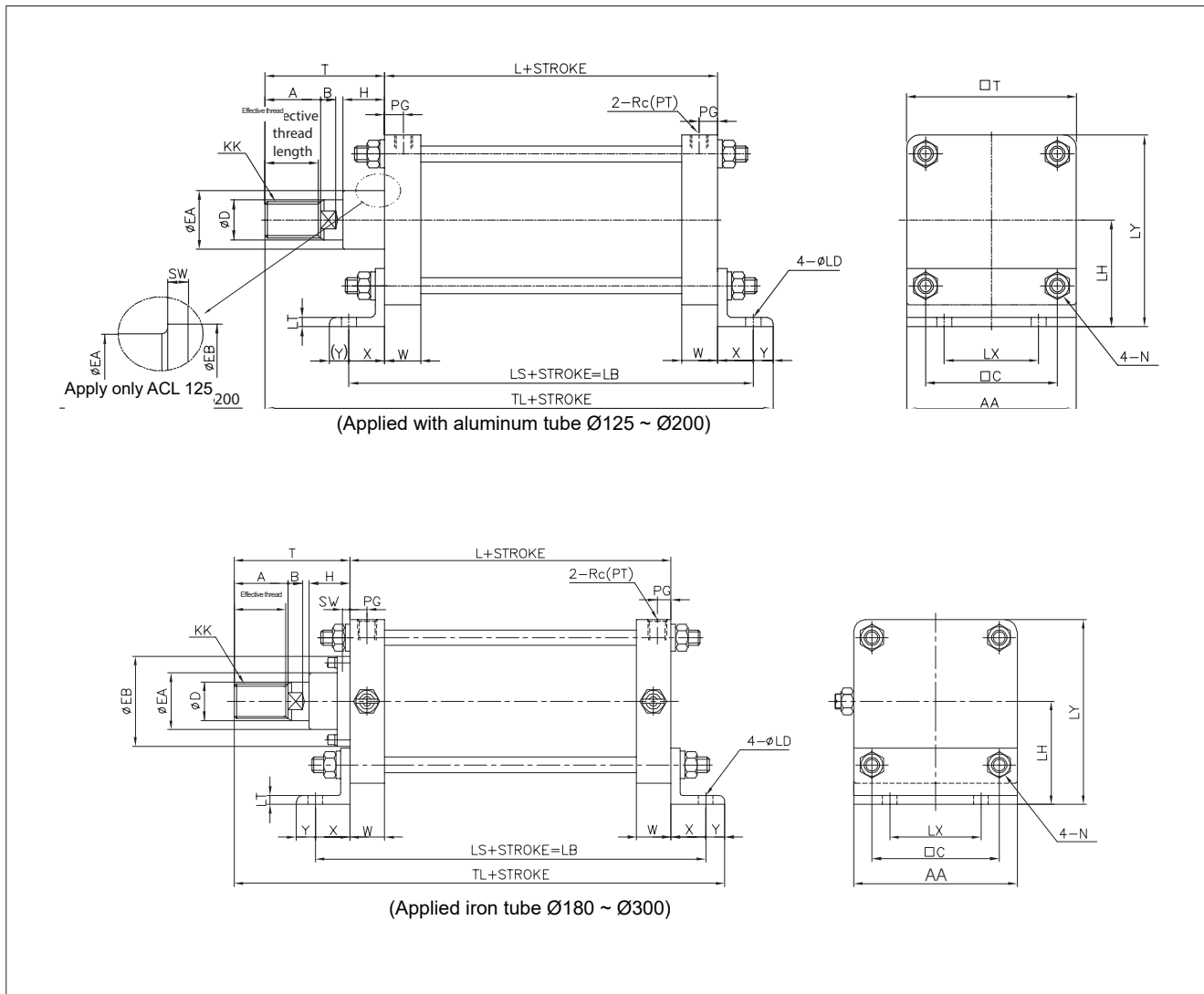

Unit : mm

Bore size	Effective thread length	A	AA	B	□C	ØD	ØEA	ØEB	H	KK	L	ØLD	LH	LS	LT
Ø125	47	50	145	15	115	35	55	-	43	M30X1.5	98	19	85	188	8
Ø140	47	50	161	15	128	35	59	61	42	M30X1.5	98	19	100	188	9
Ø150	53	56	170	17	132	40	59	61	43	M36X1.5	106	19	105	206	9
Ø160	53	56	184	17	144	40	59	61	43	M36X1.5	106	19	106	206	9
Ø180	60	63	204	20	162	45	70	115(85)	48	M40X1.5	111	24	125	231	10
Ø200	60	63	226	20	182	50	74(70)	115(85)	48	M45X1.5	111	24	132	231	10
Ø250	67	71	277	25	225	60	96	140	60	M56X2.0	141	29	160	301	12
Ø300	76	80	330	30	270	70	96	140	60	M64X2.0	146	33	200	326	15

Bore size	LX	LY	N	PG	Rc(PT)	SW	T	□T	TL	W	X	Y
Ø125	100	157.5	M14X1.5	16	1/2	-	110	145	273	32	45	(20)
Ø140	112	180.5	M14X1.5	16	1/2	8	110	161	273	32	45	(20)
Ø150	118	190	M16X1.5	17.5	3/4	8	120	170	301	36	50	(25)
Ø160	118	198	M16X1.5	17	3/4	8	120	184	301	36	50	(25)
Ø180	132	227	M18X1.5	17	3/4	17	135	204	336	39	60	(30)
Ø200	150	245	M20X1.5	16.5	3/4	17	135	226	336	39	60	(30)
Ø250	180	298.5	M24X1.5	22	1	20	160	277	421	49	80	(40)
Ø300	212	365	M30X1.5	22	1	20	175	330	451	49	90	(40)

※ ØEA, ØEB () dimensions are for aluminum cover.

Dimensions-Rod Side Flange (FA)

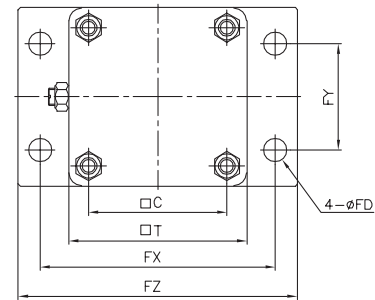
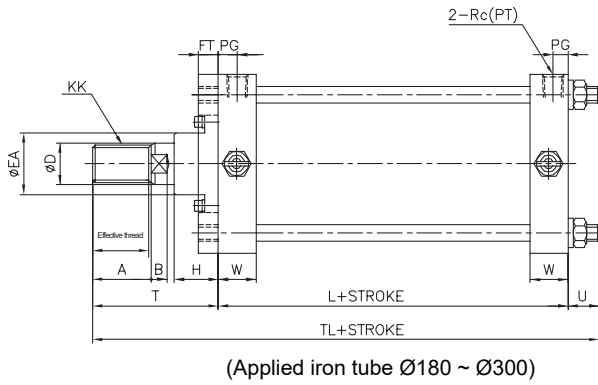
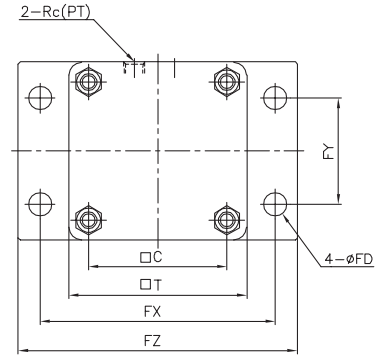
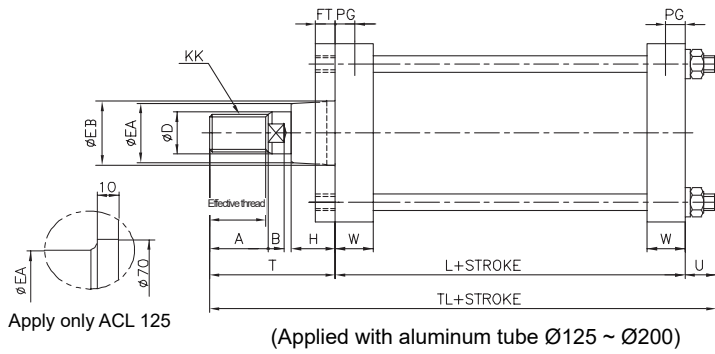

Unit : mm

Bore size	Effective thread length	A	B	□C	ØD	ØEA	ØEB	ØFD	FT	FX	FY	FZ	H	KK
Ø125	47	50	15	115	35	55	-	19	14	190	100	230	43	M30X1.5
Ø140	47	50	15	128	35	59	61	19	20	212	112	255	42	M30X1.5
Ø150	53	56	17	132	40	59	61	19	20	228	115	265	43	M36X1.5
Ø160	53	56	17	144	40	59	61	19	20	236	118	275	43	M36X1.5
Ø180	60	63	20	162	45	70	115(85)	24	25	265	132	320	48	M40X1.5
Ø200	60	63	20	182	50	74(70)	115(85)	24	25	280	150	335	48	M45X1.5
Ø250	67	71	25	225	60	96	140	29	30	355	180	420	60	M56X2.0
Ø300	76	80	30	270	70	96	140	33	30	400	212	475	60	M64X2.0

Bore size	L	N	PG	Rc(PT)	□T	T	TL	U	W	W
Ø125	98	M14X1.5	16	1/2	145	110	233	(25)	32	32
Ø140	98	M14X1.5	16	1/2	161	110	233	(25)	32	32
Ø150	106	M16X1.5	17.5	3/4	170	120	253	(27)	36	36
Ø160	106	M16X1.5	17	3/4	184	120	253	(27)	36	36
Ø180	111	M18X1.5	17	3/4	204	135	276	(30)	39	39
Ø200	111	M20X1.5	16.5	3/4	226	135	281	(35)	39	38
Ø250	141	M24X1.5	22	1	277	160	341	(40)	49	49
Ø300	146	M30X1.5	22	1	330	175	370	(49)	49	49

* ØEA, ØEB () dimensions are for aluminum cover.

Dimensions-Head Side Flange (FB)

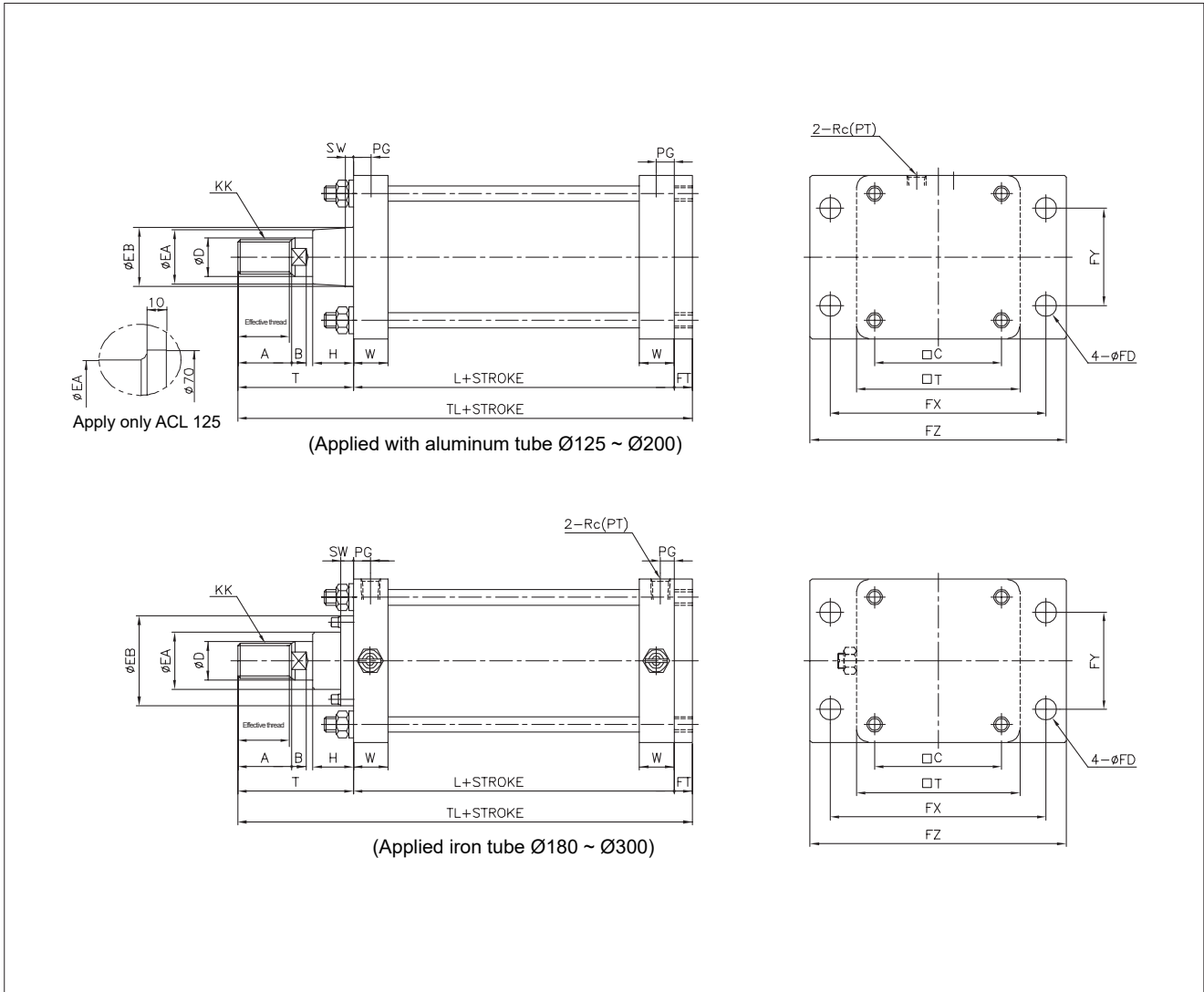

Unit : mm

Bore size	Effective thread length	A	B	□C	ØD	ØEA	ØEB	ØFD	FT	FX	FY	FZ	H	KK
Ø125	47	50	15	115	35	55	-	19	14	190	100	230	43	M30X1.5
Ø140	47	50	15	128	35	59	61	19	20	212	112	255	42	M30X1.5
Ø150	53	56	17	132	40	59	61	19	20	228	115	265	43	M36X1.5
Ø160	53	56	17	144	40	59	61	19	20	236	118	275	43	M36X1.5
Ø180	60	63	20	162	45	70	115(85)	24	25	265	132	320	48	M40X1.5
Ø200	60	63	20	182	50	74(70)	115(85)	24	25	280	150	335	48	M45X1.5
Ø250	67	71	25	225	60	96	140	29	30	355	180	420	60	M56X2.0
Ø300	76	80	30	270	70	96	140	33	30	400	212	475	60	M64X2.0

Bore size	L	N	PG	Rc(PT)	SW	□T	T	TL	W
Ø125	98	M14X1.5	16	1/2	-	145	110	222	32
Ø140	98	M14X1.5	16	1/2	8	161	110	228	32
Ø150	106	M16X1.5	17.5	3/4	8	170	120	246	36
Ø160	106	M16X1.5	17	3/4	8	184	120	246	36
Ø180	111	M18X1.5	17	3/4	17	204	135	271	39
Ø200	111	M20X1.5	16.5	3/4	17(8)	226	135	271	39
Ø250	141	M24X1.5	22	1	20	277	160	331	49
Ø300	146	M30X1.5	22	1	20	330	175	351	49

※ ØEA, ØEB, SW () dimensions are for aluminum cover.

Dimensions-Single Clevis (CA)

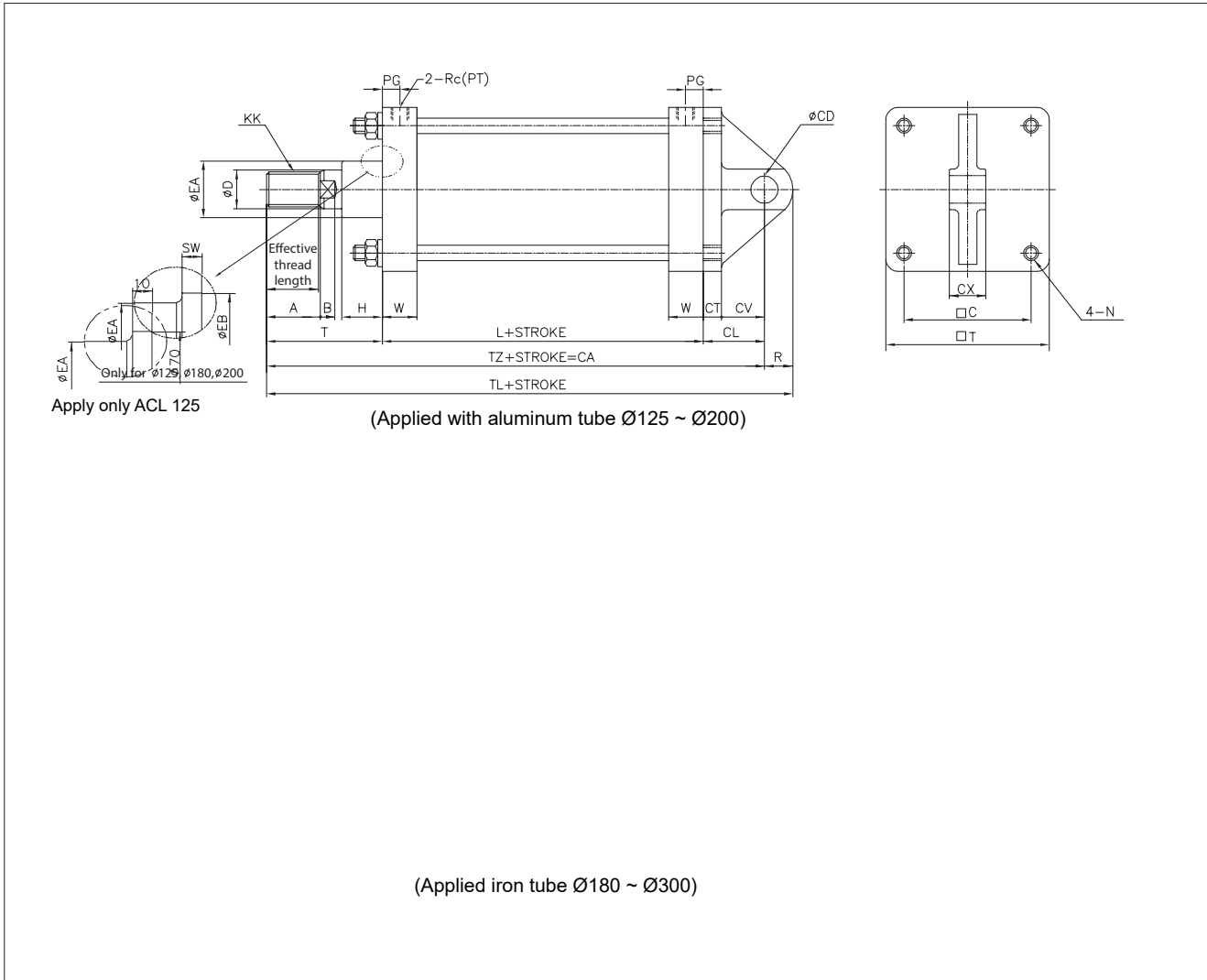

Unit : mm

Bore size	Effective thread length	A	B	□C	ØCD	CL	CT	CV	CX	ØD	ØEA	ØEB	H
Ø125	47	50	15	115	25 ^{+0.10} ₀	65	19	46	32 ^{-0.1} _{-0.3}	35	55	-	43
Ø140	47	50	15	128	28 ^{+0.10} ₀	75	19	56	36 ^{-0.1} _{-0.3}	35	59	61	42
Ø150	53	56	17	132	32 ^{+0.10} ₀	80	20	60	40 ^{-0.1} _{-0.3}	40	59	61	43
Ø160	53	56	17	144	32 ^{+0.10} ₀	80	20	60	40 ^{-0.1} _{-0.3}	40	59	61	43
Ø180	60	63	20	162	40 ^{+0.10} ₀	90	23	67	50 ^{-0.1} _{-0.3}	45	70	115(85)	48
Ø200	60	63	20	182	40 ^{+0.10} ₀	90	25	65	50 ^{-0.1} _{-0.3}	50	74(70)	115(85)	48
Ø250	67	71	25	225	50 ^{+0.10} ₀	110	30	80	63 ^{-0.1} _{-0.3}	60	96	140	60
Ø300	76	80	30	270	63 ^{+0.12} ₀	130	37	93	80 ^{-0.1} _{-0.3}	70	96	140	60

Bore size	KK	L	N	PG	Rc(PT)	R	SW	□T	T	TL	TZ	W
Ø125	M30X1.5	98	M14X1.5	16	1/2	29	-	145	110	302	273	32
Ø140	M30X1.5	98	M14X1.5	16	1/2	32	8	161	110	315	283	32
Ø150	M36X1.5	106	M16X1.5	17.5	3/4	36	8	170	120	342	306	36
Ø160	M36X1.5	106	M16X1.5	17	3/4	36	8	184	120	342	306	36
Ø180	M40X1.5	111	M18X1.5	17	3/4	44	17	204	135	380	336	39
Ø200	M45X1.5	111	M20X1.5	16.5	3/4	44	17(8)	226	135	380	336	39
Ø250	M56X2.0	141	M24X1.5	22	1	55	20	277	160	466	411	49
Ø300	M64X2.0	146	M30X1.5	22	1	68	20	330	175	519	451	49

* ØEA, ØEB, SW () dimensions are for aluminum cover.

Dimensions-Double Clevis (CB)

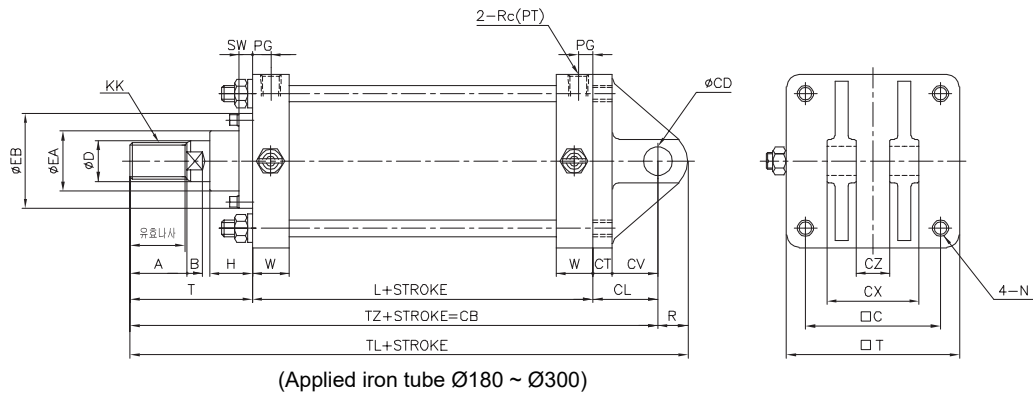
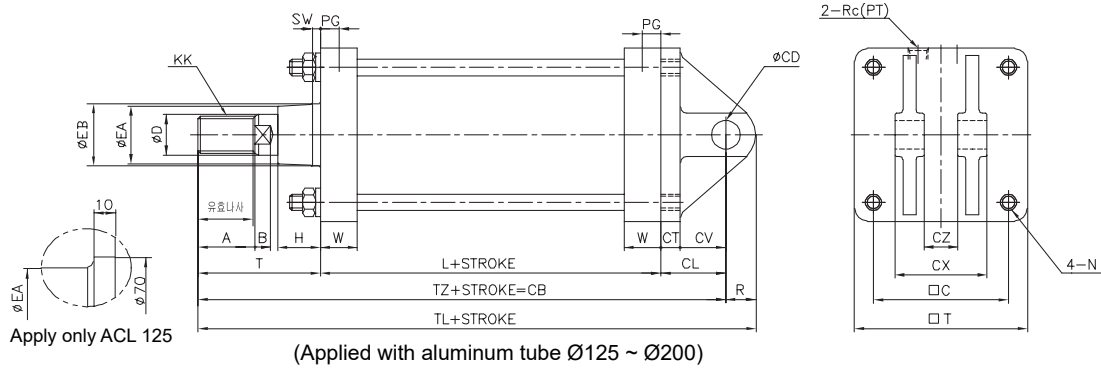

Unit : mm

Bore size	Effective thread length	A	B	□C	ØCD	CL	CT	CV	CX	CZ	ØD	ØEA	ØEB	H
Ø125	47	50	15	115	25 ^{+0.15} / _{+0.10}	65	19	46	64	32 ^{+0.3} / _{+0.1}	35	55	-	43
Ø140	47	50	15	128	28 ^{+0.15} / _{+0.10}	75	19	56	72	36 ^{+0.3} / _{+0.1}	35	59	61	42
Ø150	53	56	17	132	32 ^{+0.15} / _{+0.10}	80	20	60	80	40 ^{+0.3} / _{+0.1}	40	59	61	43
Ø160	53	56	17	144	32 ^{+0.15} / _{+0.10}	80	20	60	80	40 ^{+0.3} / _{+0.1}	40	59	61	43
Ø180	60	63	20	162	40 ^{+0.15} / _{+0.10}	90	23	67	100	50 ^{+0.3} / _{+0.1}	45	70	115(85)	48
Ø200	60	63	20	182	40 ^{+0.15} / _{+0.10}	90	25	65	100	50 ^{+0.3} / _{+0.1}	50	74(70)	115(85)	48
Ø250	67	71	25	225	50 ^{+0.15} / _{+0.10}	110	30	80	126	63 ^{+0.3} / _{+0.1}	60	96	140	60
Ø300	76	80	30	270	63 ^{+0.15} / _{+0.10}	130	37	93	160	80 ^{+0.3} / _{+0.1}	70	96	140	60

Bore size	KK	L	N	PG	R	Rc(PT)	SW	□T	T	TL	TZ	W
Ø125	M30X1.5	98	M14X1.5	16	(29)	1/2	-	145	110	302	273	32
Ø140	M30X1.5	98	M14X1.5	16	(32)	1/2	8	161	110	315	283	32
Ø150	M36X1.5	106	M16X1.5	17.5	(36)	3/4	8	170	120	342	306	36
Ø160	M36X1.5	106	M16X1.5	17	(36)	3/4	8	184	120	342	306	36
Ø180	M40X1.5	111	M18X1.5	17	(44)	3/4	17	204	135	380	336	39
Ø200	M45X1.5	111	M20X1.5	16.5	(44)	3/4	17(8)	226	135	380	336	39
Ø250	M56X2.0	141	M24X1.5	22	(55)	1	20	277	160	466	411	49
Ø300	M64X2.0	146	M30X1.5	22	(68)	1	20	330	175	519	451	49

* ØEA, ØEB, SW () dimensions are for aluminum cover.

Dimensions-Center Trunnion (TC), Rod Side Trunnion (TA), Head Side Trunnion (TB)

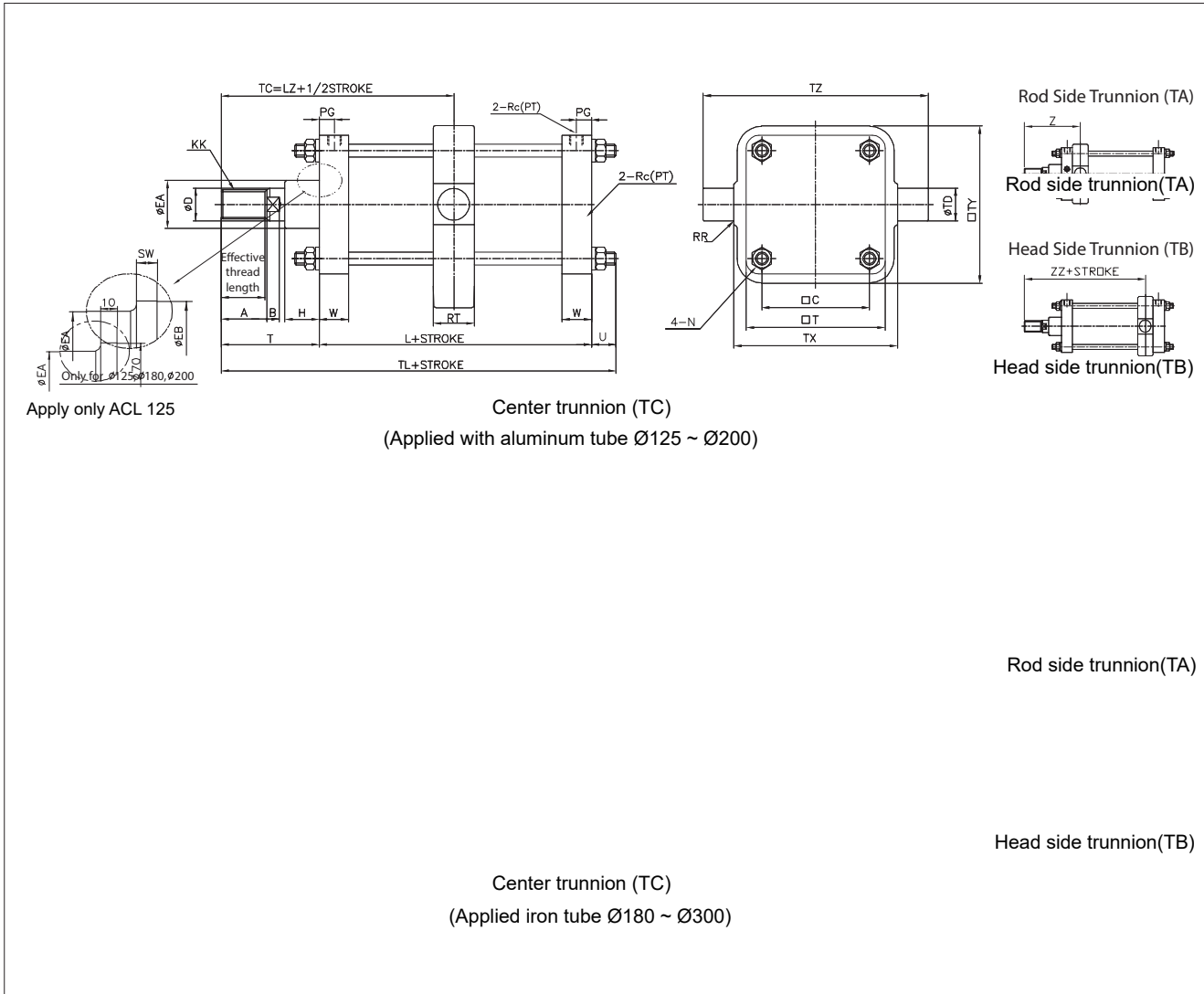

Unit : mm

Bore size	Effective thread length	A	B	□C	∅D	∅EA	∅EB	H	KK	L	LZ	N	PG	Rc(PT)
∅125	47	50	15	115	35	55	-	43	M30X1.5	98	159	M14X1.5	16	1/2
∅140	47	50	15	128	35	59	61	42	M30X1.5	98	159	M14X1.5	16	1/2
∅150	53	56	17	132	40	59	61	43	M36X1.5	106	173	M16X1.5	17.5	3/4
∅160	53	56	17	144	40	59	61	43	M36X1.5	106	173	M16X1.5	17	3/4
∅180	60	63	20	162	45	70	115(85)	48	M40X1.5	111	190.5	M18X1.5	17	3/4
∅200	60	63	20	182	50	74(70)	115(85)	48	M45X1.5	111	190.5	M20X1.5	16.5	3/4
∅250	67	71	25	225	60	96	140	60	M56X2.0	141	230.5	M24X1.5	22	1
∅300	76	80	30	270	70	96	140	60	M64X2.0	146	248	M30X1.5	22	1

Bore size	RR	RT	SW	□T	T	∅TD	TL	TX	□TY	TZ	U	W	Z	ZZ
∅125	1	50	-	145	110	32 ^{-0.05} _{-0.10}	227	170	164	234	(19)	32	167	151
∅140	1.5	55	8	161	110	36 ^{-0.05} _{-0.10}	227	190	184	262	(19)	32	169.5	148.5
∅150	1.5	59	8	170	120	40 ^{-0.05} _{-0.10}	248.5	200	192	275	(22.5)	36	185.5	160.5
∅160	1.5	59	8	184	120	40 ^{-0.05} _{-0.10}	248.5	212	204	292	(22.5)	36	185.5	160.5
∅180	2	60	17	204	135	45 ^{-0.05} _{-0.10}	270.5	236	228	326	(24.5)	39	204	177
∅200	2	60	17(8)	226	135	45 ^{-0.05} _{-0.10}	271.5	265	257	355	(25.5)	39	204	177
∅250	3	69	20	277	160	56 ^{-0.05} _{-0.10}	331	335	325	447	(30)	49	243.5	217.5
∅300	4	79	20	330	175	67 ^{-0.05} _{-0.10}	357.5	400	390	534	(36.5)	49	263.5	232.5

* ∅EA, ∅EB, SW () dimensions are for aluminum cover.

Dimensions-Bellows Attached Type (J, K)

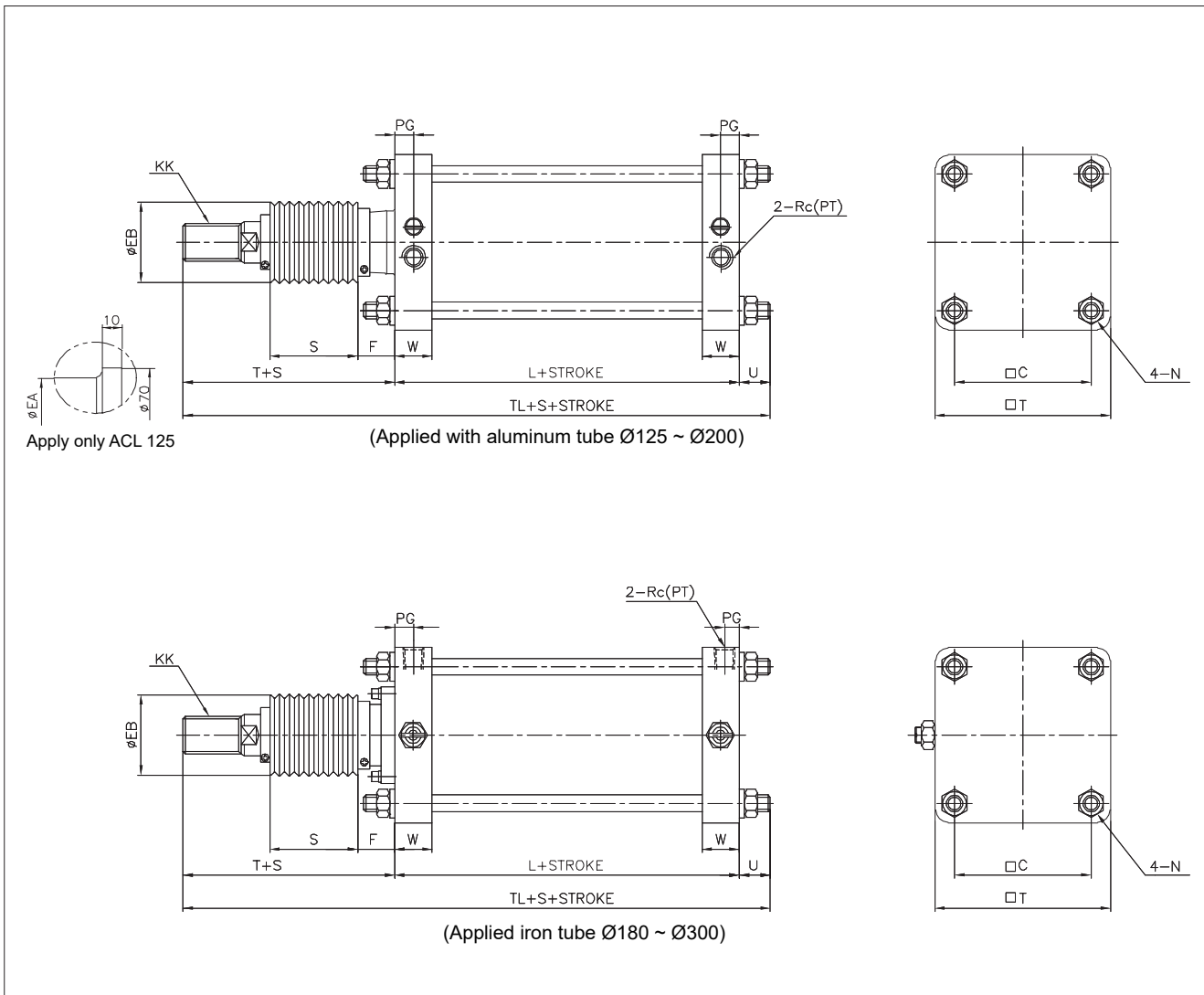

Unit : mm

Bore size	□C	ØEB	F	KK	N	L	PG	Rc(PT)	S	T	□T	TL	U	W
Ø125	115	75	40	M30X1.5	M14X1.5	98	16	1/2	0.2 X Stroke	133	145	252	(21)	32
Ø140	128	75	40	M30X1.5	M14X1.5	98	16	1/2		133	161	252	(21)	32
Ø150	132	75	40	M36X1.5	M16X1.5	106	17.5	3/4		141	170	270	(23)	36
Ø160	144	75	40	M36X1.5	M16X1.5	106	17	3/4		141	184	270	(23)	36
Ø180	162	85	45	M40X1.5	M18X1.5	111	17	3/4		153	204	290	(26)	39
Ø200	182	90	45	M45X1.5	M20X1.5	111	16.5	3/4		153	226	294	(30)	39
Ø250	225	105	55	M56X2.0	M24X1.5	141	22	1	0.17 X Stroke	176	277	351	(34)	49
Ø300	270	115	55	M64X2.0	M30X1.5	146	22	1		190	330	372.5	(36.5)	49

※ For dimensions not shown in these figures, refer to the ACL (Standard) type.
 ※ SUS band is mounted at bellows at delivery.

Type	J	K
Material	Nylon Tarpaulin	Neoprene Cloth
Temperature	60℃	110℃

Dimensions-Accessory

Single Knuckle Joint

Material: Free-cutting steel

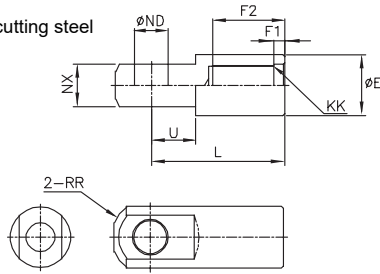

Unit : mm

Part no.	Bore size	ØE	F1	F2	KK	L	ØND
I125	125	46	8	54	M30X1.5	100	25 ^{+0.1} ₀
I140	140	48	8	54	M30X1.5	105	28 ^{+0.1} ₀
I150	150, 160	55	8	60	M36X1.5	110	32 ^{+0.1} ₀
I180	180	70	8	67	M40X1.5	125	40 ^{+0.1} ₀
I200	200	70	8	67	M45X1.5	125	40 ^{+0.1} ₀
I250	250	85	8	75.5	M56X2.0	160	50 ^{+0.1} ₀
I300	300	105	8	84.5	M64X2.0	175	63 ^{+0.1} ₀

Part no.	NX	RR(球)	U	LT
I125	32 ^{-0.1} _{-0.3}	27	33	127
I140	36 ^{-0.1} _{-0.3}	30	39	135
I150	40 ^{-0.1} _{-0.3}	34	39	144
I180	50 ^{-0.1} _{-0.3}	42.5	44	167.5
I200	50 ^{-0.1} _{-0.3}	42.5	44	167.5
I250	63 ^{-0.1} _{-0.3}	53	66	213
I300	80 ^{-0.1} _{-0.3}	66	71	241

Double Knuckle Joint

Material: FC 40

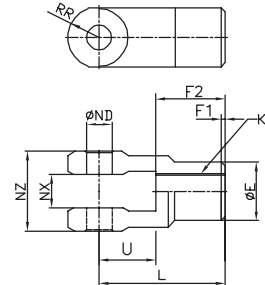

Unit : mm

Part no.	Bore size	ØE	F1	F2	KK	L	ØND
Y125	125	46	8	58	M30X1.5	100	25 ^{+0.1} ₀
Y140	140	48	8	58	M30X1.5	105	28 ^{+0.1} ₀
Y150	150, 160	55	8	64	M36X1.5	110	32 ^{+0.1} ₀
Y180	180	70	8	71	M40X1.5	125	40 ^{+0.1} ₀
Y200	200	70	8	71	M45X1.5	125	40 ^{+0.1} ₀
Y250	250	86	9	79	M56X2.0	160	50 ^{+0.1} ₀
Y300	300	105	9	88	M64X2.0	175	63 ^{+0.1} ₀

Part no.	NX	NZ	RR	U
Y125	32 ^{+0.3} _{+0.1}	64 ^{-0.1} _{-0.3}	27	42
Y140	36 ^{+0.3} _{+0.1}	72 ^{-0.1} _{-0.3}	30	47
Y150	40 ^{+0.3} _{+0.1}	80 ^{-0.1} _{-0.3}	34	46
Y180	50 ^{+0.3} _{+0.1}	100 ^{-0.1} _{-0.3}	42.5	54
Y200	50 ^{+0.3} _{+0.1}	100 ^{-0.1} _{-0.3}	42.5	54
Y250	63 ^{+0.3} _{+0.1}	126 ^{-0.1} _{-0.3}	53	81
Y300	80 ^{+0.3} _{+0.1}	160 ^{-0.1} _{-0.3}	66	87

Rod End Nut

Material: Rolled steel

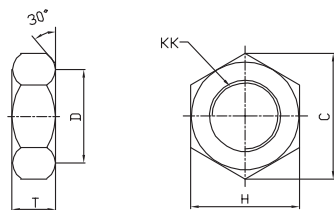

Unit : mm

Part no.	Bore size	C	D	H	KK	T
RN-12	125, 140	53.1	44	46	M30X1.5	18
RN-15	150, 160	63.5	53	55	M36X1.5	21
RN-18	180	69.3	57	60	M40X1.5	23
RN-20	200	80.8	67	70	M45X1.5	27
RN-25	250	98.1	82	85	M56X2.0	34
RN-30	300	110	92	95	M64X2.0	38

Knuckle Joint Pin/ Clevis Pin

Material: Carbon Steel

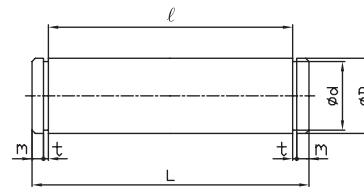

Unit : mm

Part no.	Bore size	ØD	Ød	L	ℓ	m	t
CJP-12	125	25 ^{-0.06} _{-0.11}	23.9 ⁰ _{-0.21}	72	64.3	2.5	1.35
CJP-14	140	28 ^{-0.06} _{-0.11}	26.6 ⁰ _{-0.21}	80.6	72.3	2.5	1.65
CJP-15	150, 160	32 ^{-0.08} _{-0.14}	30.3 ⁰ _{-0.25}	89.6	80.3	3	1.65
CJP-18	180, 200	40 ^{-0.08} _{-0.14}	38 ⁰ _{-0.25}	110.1	100.3	3	1.9
CJP-25	250	50 ^{-0.08} _{-0.11}	47 ⁰ _{-0.25}	138.9	126.5	4	2.2
CJP-30	300	63 ^{-0.10} _{-0.17}	60 ⁰ _{-0.3}	172.9	160.5	4	2.2

Dimensions-Double Rod (ACLW)

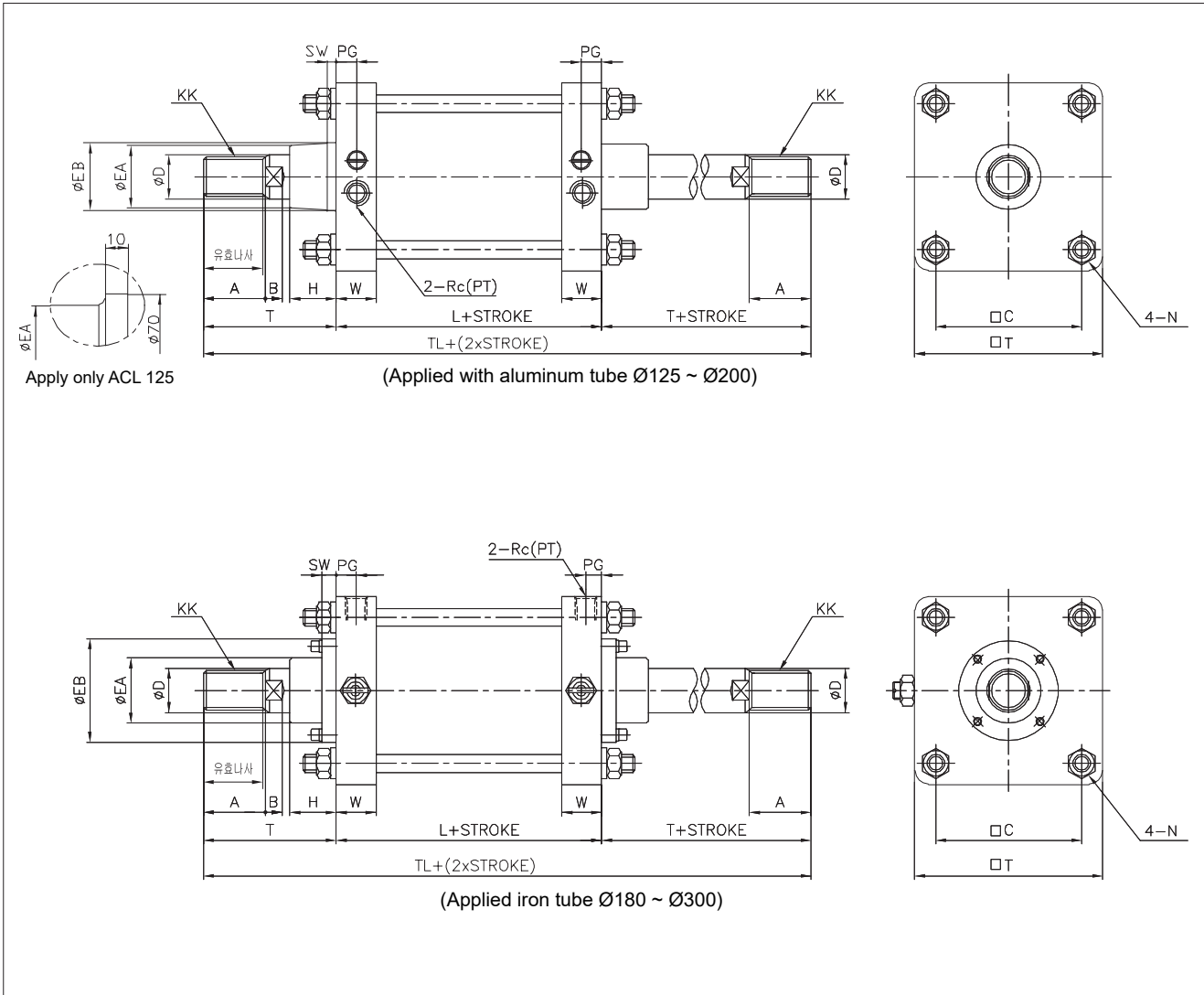

Unit : mm

Bore size	Effective thread length	A	B	□C	ØD	ØEA	ØEB	H	KK	L	N	PG	Rc(PT)	SW
Ø125	47	50	15	115	35	55	-	43	M30X1.5	98	M14X1.5	16	1/2	-
Ø140	47	50	15	128	35	59	61	42	M30X1.5	98	M14X1.5	16	1/2	8
Ø150	53	56	17	132	40	59	61	43	M36X1.5	106	M16X1.5	17.5	3/4	8
Ø160	53	56	17	144	40	59	61	43	M36X1.5	106	M16X1.5	17	3/4	8
Ø180	60	63	20	162	45	70	115(85)	48	M40X1.5	111	M18X1.5	17	3/4	17
Ø200	60	63	20	182	50	74(70)	115(85)	48	M45X1.5	111	M20X1.5	16.5	3/4	17(8)
Ø250	67	71	25	225	60	96	140	60	M56X2.0	141	M24X1.5	22	1	20
Ø300	76	80	30	270	70	96	140	60	M64X2.0	146	M30X1.5	22	1	20

Bore size	□T	T	TL	W
Ø125	145	110	318	32
Ø140	161	110	318	32
Ø150	170	120	346	36
Ø160	184	120	346	36
Ø180	204	135	381	39
Ø200	226	135	381	39
Ø250	277	160	461	49
Ø300	330	175	496	49

* ØEA, ØEB, SW () dimensions are for aluminum cover.

Single Rod Multi-Step Stroke Cylinder (TS)

By integrating two cylinders in series enable back and forth stroke and two-steps control for a doubled output.

Ordering notation: A Stroke + Total Stroke

Ex) 150 + 200 (A Side = 150, B Side = 50)

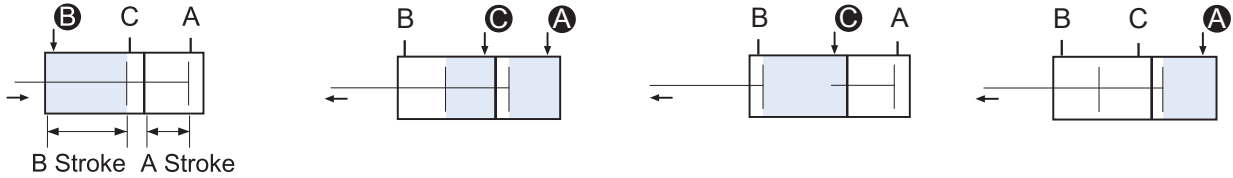

When B port is supplied with air pressure, A and B strokes reverse.

When both A and C ports are supplied with air pressure, forward output is doubled.

When C port is supplied with air pressure, rod and B Stroke move forward.

When A port is supplied with air pressure, rod and A Stroke move forward.

Dimensions-Single Rod Multi-Step Stroke Cylinder (TS)

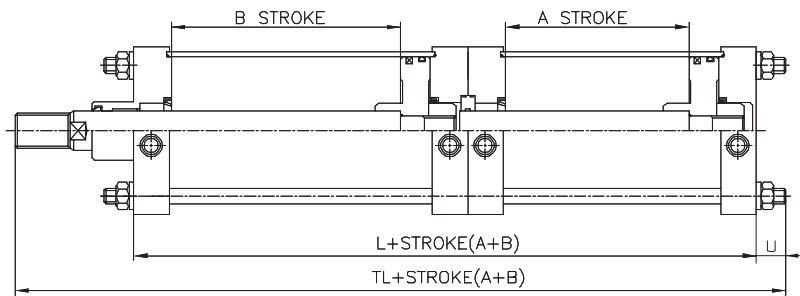
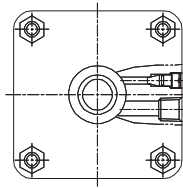

(Applied with aluminum tube $\varnothing 125 \sim \varnothing 200$)

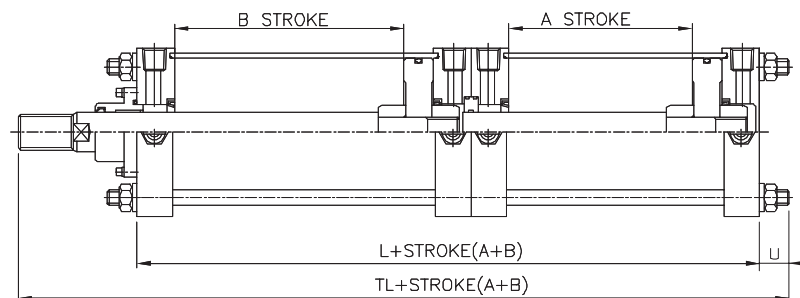
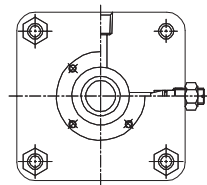

(Applied iron tube $\varnothing 180 \sim \varnothing 300$)

Unit : mm

Bore size	L	TL	U
$\varnothing 125$	196	327	(21)
$\varnothing 140$	196	327	(21)
$\varnothing 150$	213	363.5	(23)
$\varnothing 160$	213	363.5	(23)
$\varnothing 180$	223	393	(26)
$\varnothing 200$	223	393	(30)
$\varnothing 250$	283	484.5	(34)
$\varnothing 300$	293	519.5	(41.5)

* For dimensions not shown in these figures, refer to the ACL (Standard) type.

Double Rod Multi-Step Stroke Cylinder (TW)

Head side assembly. By integrating two cylinders enable back and forth stroke and three steps control.

Ordering notation: A Stroke + B Stroke

Example) 150 + 200 (A Side = 150, B Side = 200)

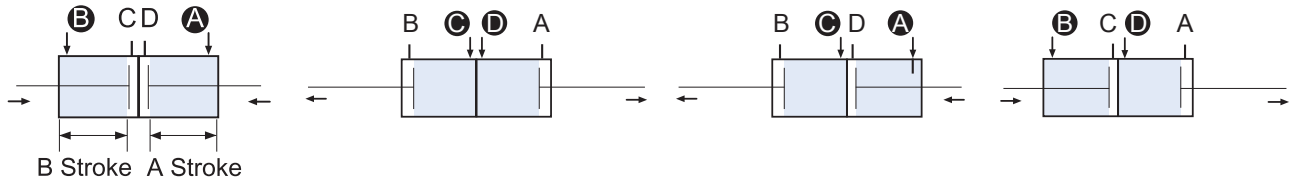

When A and B ports are supplied with air pressure, A and B strokes reverse.

When C and D ports are supplied with air pressure, A and B strokes move forward.

When A and C ports are supplied with air pressure, B stroke move forward.

When B and D ports are supplied with air pressure, A stroke move forward.

Dimensions-Double Rod Multi-Step Stroke Cylinder (TW)

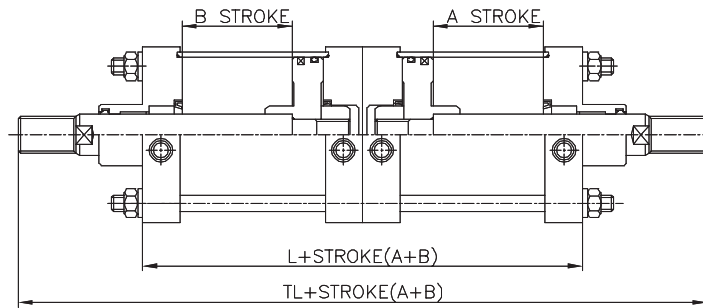
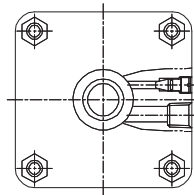

(Applied with aluminum tube $\varnothing 125 \sim \varnothing 200$)

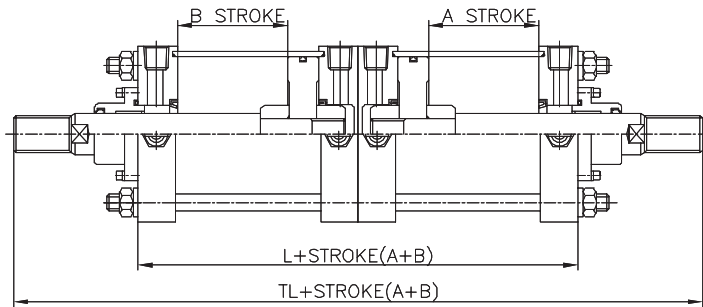
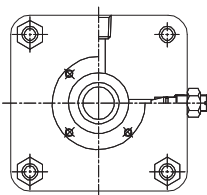

(Applied iron tube $\varnothing 180 \sim \varnothing 300$)

Unit : mm

Bore size	L	TL
$\varnothing 125$	196	416
$\varnothing 140$	196	416
$\varnothing 150$	212	452
$\varnothing 160$	212	452
$\varnothing 180$	222	492
$\varnothing 200$	222	492
$\varnothing 250$	282	602
$\varnothing 300$	292	642

* For dimensions not shown in these figures, refer to the ACL (Standard) type.

Tandem Cylinder (TD)

Two cylinders connected in series for a doubled output.



When A and B ports are supplied with air pressure, reverse operating output is doubled.

When A and C ports are supplied with air pressure, forward operating output is doubled.

Dimensions-Tandem Cylinder (TD)

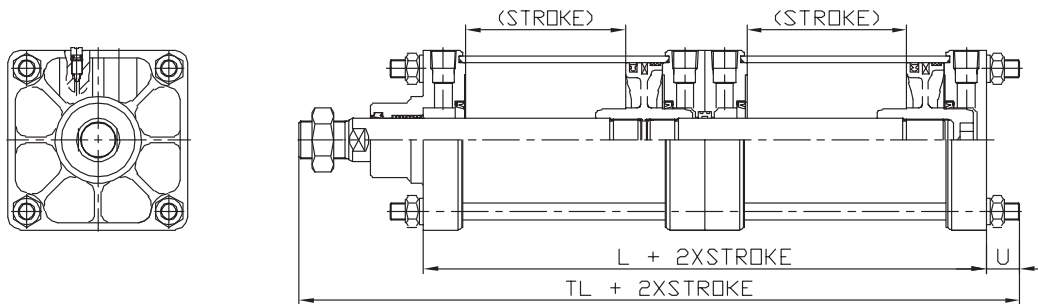

(Applied with aluminum tube $\varnothing 125 \sim \varnothing 200$)

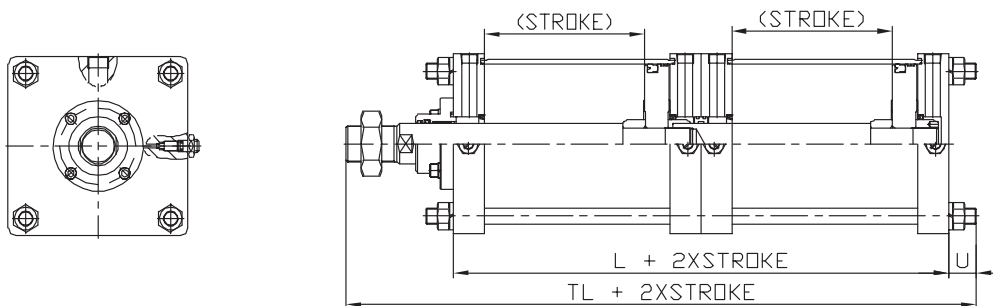

(Applied iron tube $\varnothing 180 \sim \varnothing 300$)

Unit : mm

Bore size	L	TL	U
$\varnothing 125$	196	327	(21)
$\varnothing 140$	196	327	(21)
$\varnothing 150$	212	355	(23)
$\varnothing 160$	212	355	(23)
$\varnothing 180$	222	383	(26)
$\varnothing 200$	222	387	(30)
$\varnothing 250$	282	476	(34)
$\varnothing 300$	292	508.5	(41.5)

※ For dimensions not shown in these figures, refer to the ACL (Standard) type.

Forward Stroke Adjustable Cylinder (ASJ, BSJ)

To adjust the entire forward stroke from 0mm to 50mm an adjustment mechanism is attached to the head side.

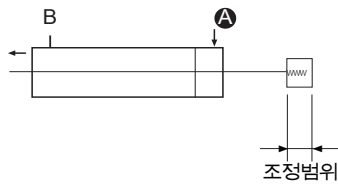

ASJ : 25mm adjustment
BSJ : 50mm adjustment
XSJ : Xmm adjustment (X is defined by user)

Dimensions-Forward Stroke Adjustable (ASJ, BSJ)

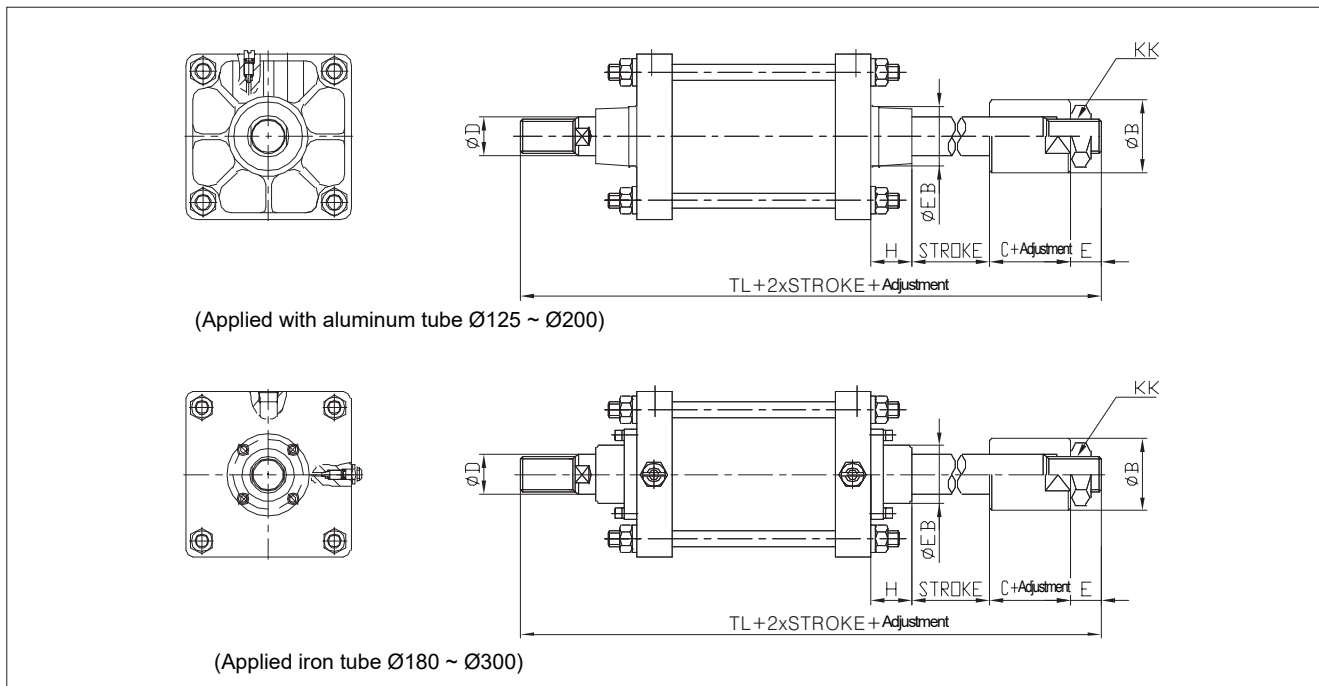

Unit : mm

Bore size	ØB	C	ØD	E	ØEB	H	KK	TL
Ø125	60	37	35	39	90	43	M30X1.5	318
Ø140	60	37	35	30	90	43	M30X1.5	318
Ø150	60	46	40	26	90	43	M36X1.5	341
Ø160	60	46	40	26	90	43	M36X1.5	341
Ø180	70	52	45	30	115	48	M40X1.5	376
Ø200	70	52	50	30	115	48	M45X1.5	376
Ø250	86	60	60	35	140	60	M56X2.0	456
Ø300	86	60	70	35	140	60	M64X2.0	496

※ For dimensions not shown in these figures, refer to the ACL standard type.

Heat Resistant Cylinder (SV)

Heat resistant cylinder can be used at a high ambient temperature up to 150°C by equipped with heat-resistant seal.

Specification

Type	Lubricated type
Bore size	Ø125, Ø140, Ø150, Ø160, Ø180, Ø200
Ambient temperature	-20 ~ 150°C
Packing material	VITON

Stainless Steel Piston Rod (SS)

Stainless steel cylinder rod is selected to prevent the end of rod from corrosion when it is in contact with water during operation.

Specification

Type	Lubricated type, Non-Lubricated type
Bore size	Ø125, Ø140, Ø150, Ø160, Ø180, Ø200, Ø250, Ø300
Rod material	SUS304

Cold resistant cylinder (LT)

This cylinder is equipped with cold packing so that it can be used at a low temperature up to -40°C.

Specification

Fluid	Non-lubricated
Bore size	Ø125, Ø140, Ø150, Ø160, Ø180, Ø200, Ø250, Ø300
Ambient & fluid temperature	-40°C~70°C
Used grease	Cold resistant grease
Packing material	Low nitrile rubber

※ Caution: Please be sure to install an air dryer, water separator and filter before use, as freezing may occur due to moisture inside the compressed air.

Air pressure in low temperature range

Due to extreme temperature conditions, the limit of application of our products increases and there may be a noticeable deviation from catalog information.

- * Shorten durability
- * Increased leakage
- * Silicon-containing fuel
- * Dynamic change of value

When designing a new system, you should clarify with us about the above items.

Also, a simple transfer of air pressure is not always possible.

Most components are not available for small temperature changes.

Therefore, a whole new system concept must be developed.

The stringent reliability of pneumatic equipment is the quality of the compressed air used.

Technical data

- ※ In the temperature range -30 °C to 80 °C, the quality of compressed air is ISO8573 class 2
- ※ In the temperature range -40 °C to 80 °C, the quality of compressed air is ISO8573 Class 1

Criteria for using compressed air at operating temperatures up to dew point (Kelvin temperature of approximately 10 degrees K or less) are generally specified. Compressed air should not be exposed to antifreeze under any circumstances because the effects on our products or materials cannot be predicted.

Low friction cylinder (Q)

The sliding resistance is small, it can be used at low pressure, and smooth operation is possible even at low speed.

Specification

Fluid	Non-lubricated
Low friction direction	One direction (R-AIR supply, H-AIR supply)
Proof pressure	10.5kgf/cm ² (1.05MPa)
Max. operating pressure	9.9kgf/cm ² (0.99MPa)
Min. operating pressure	0.2kgf/cm ² (0.02MPa)
Cushion	None
Internal leakage (Central tendency)	≤ 0.5 l / min (ANR)
Ambient & fluid temperature	-10~60°C

Selection and example of low friction direction

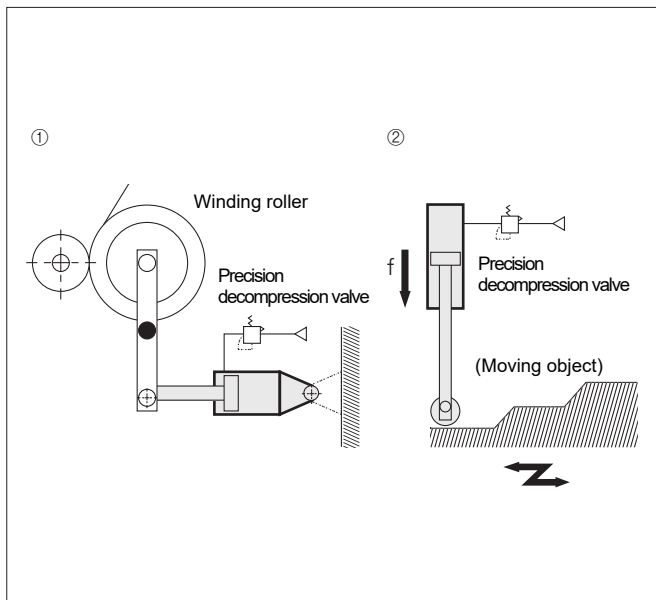

1. When using in balance, etc., pressurize only from the port of one side type as in the example of use, and leave the other ports at atmospheric pressure.

When pressurized by the rod cover port:

Low friction direction R side (Example of use ①)

When pressurized by the headcover port:

Low friction direction H side (Example of use ②)

In any case, when the piston rod is moved by an external force, it operates low friction in the forward and reverses directions.

2. Refer to the above ① in case of pressurizing at both ports simultaneously.

When the direction of the rod cover port is relatively high pressure:

Low friction direction R

When headcover port is relatively high pressure:

Low friction direction H

※ Use low friction cylinders in combination with precision pressure reducing valves.

Sliding resistance of low friction side

