

# KHS series

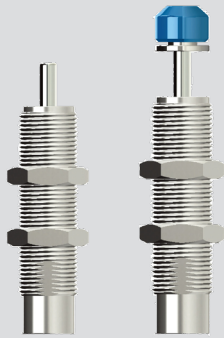

Non-Adjustable

### Features

- Compact length for use in narrow work environments

### How to Order

KHS 08 06   -  

①            ②            ③            ④

① Outer diameter

|    |          |    |       |
|----|----------|----|-------|
| 10 | M10XP1.0 | 06 | 6 mm  |
| 10 | M10XP1.0 | 08 | 8 mm  |
| 14 | M14XP1.5 | 12 | 12 mm |
| 20 | M20XP1.5 | 15 | 15 mm |

② Stroke

③ Cap

|     |                               |
|-----|-------------------------------|
| Nil | Without cap                   |
| B   | Urethane cap                  |
| T   | Steel head cap(Only M14, M20) |

④ Finishing

|   |                       |
|---|-----------------------|
| N | Nickel plating(Basic) |
|---|-----------------------|

### Specifications

| Model      | Stroke (mm) | Total energy [MAX] (Nm) | Total energy per hour [MAX] (Nm/h) | Effective weight [MIN-MAX] (kg) | Shock force [MAX] (N) | Return force [MIN-MAX] (N) | Weight (g) |
|------------|-------------|-------------------------|------------------------------------|---------------------------------|-----------------------|----------------------------|------------|
| KHS1006-N  | 6           | 3                       | 9000                               | Less 7                          | 560                   | 4~6                        | 20         |
| KHS1006B-N |             |                         |                                    |                                 |                       |                            | 22         |
| KHS1008-N  | 8           | 4                       | 10000                              | Less 9                          | 620                   | 4~6                        | 22         |
| KHS1006B-N |             |                         |                                    |                                 |                       |                            | 24         |
| KHS1412-N  | 12          | 15                      | 27000                              | Less 14                         | 1300                  | 7~11                       | 62         |
| KHS1412B-N |             |                         |                                    |                                 |                       |                            | 70         |
| KHS2015-N  | 15          | 30                      | 35000                              | Less 16                         | 1900                  | 10~30                      | 134        |
| KHS2015B-N |             |                         |                                    |                                 |                       |                            | 154        |

Dimensions

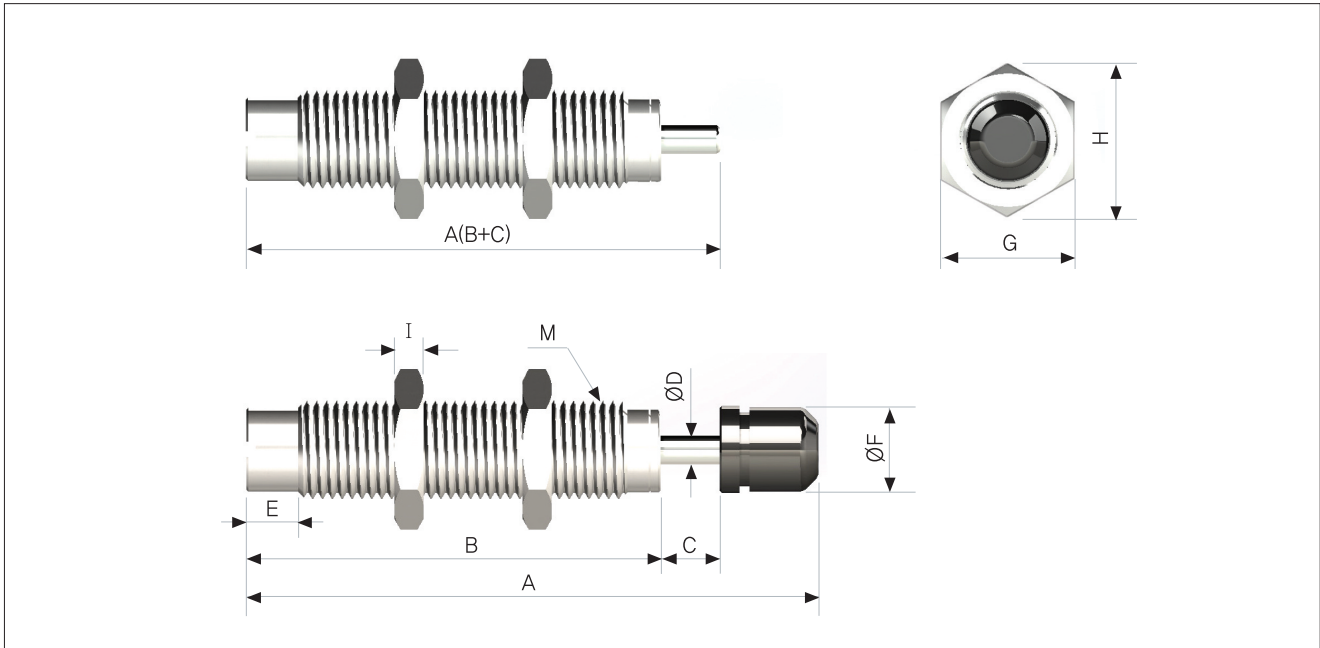

| Model      | Stroke | A  | B  | C | ØD | E | F   | G  | H    | I | M        |
|------------|--------|----|----|---|----|---|-----|----|------|---|----------|
| KHS1006-N  | 6      | 48 | 42 | 6 | 3  | 5 | -   | 14 | 16.1 | 3 | M10X1.0P |
| KHS1006B-N |        | 58 |    |   |    |   | 8.8 |    |      |   |          |
| KHS1008-N  | 8      | 52 | 44 | 8 | 3  | 5 | -   | 14 | 16.1 | 3 | M10X1.0P |
| KHS1006B-N |        | 62 |    |   |    |   | 8.8 |    |      |   |          |

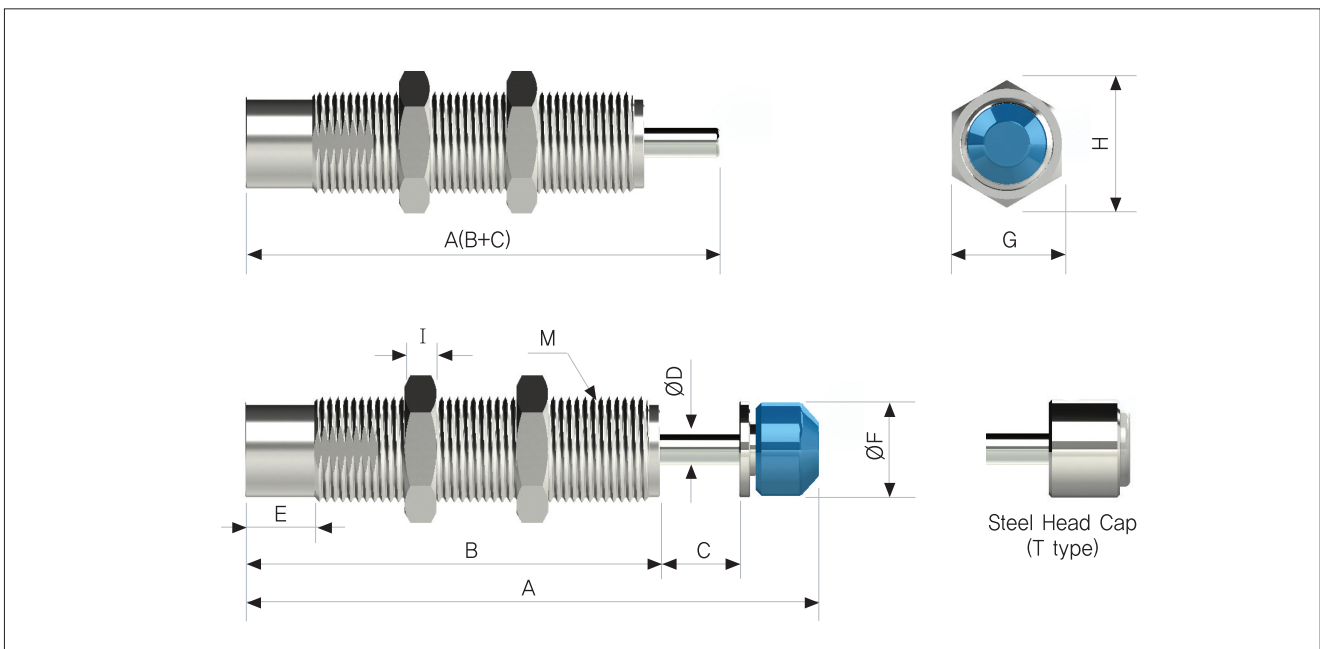

| Model      | Stroke | A   | B  | C  | ØD | E  | F  | G  | H    | I | M        |
|------------|--------|-----|----|----|----|----|----|----|------|---|----------|
| KHS1412-N  | 12     | 82  | 70 | 12 | 4  | 11 | -  | 19 | 21.9 | 4 | M14X1.5P |
| KHS1412B-N |        | 95  |    |    |    |    | 12 |    |      |   |          |
| KHS2015-N  | 15     | 93  | 78 | 15 | 6  | 13 | -  | 24 | 27.7 | 6 | M20X1.5P |
| KHS2015B-N |        | 108 |    |    |    |    | 18 |    |      |   |          |