

DSB2 series



Features

- No spring
- Horizontal port direction
- Male thread mounting

Symbol



How to Order

DSB2 - 10 R -

① ② ③ ④

① Pad diameter

Refer to dimension 'A' in dimension table

③ Material

R	NBR
S	Silicon
V	Viton
U	Urethane

※ Consult KCC for V, U type.

② Pad type

Nil	Basic
A	Compact
B	Bellows
3B	3 Stage Bellows
F	Flat

④ Special option

Nil	Standard
CS,CST	Mark free type
ASE	Static electricity free type
HTS	High temperature resistant type

※ CS, CST : With special pad coating, it prevents pad from leaving suction mark on workpiece surface (Ex. Glass or LCD surface).

※ Consult KCC for special type pad.

※ Special type has M.O.Q.

Dimensions

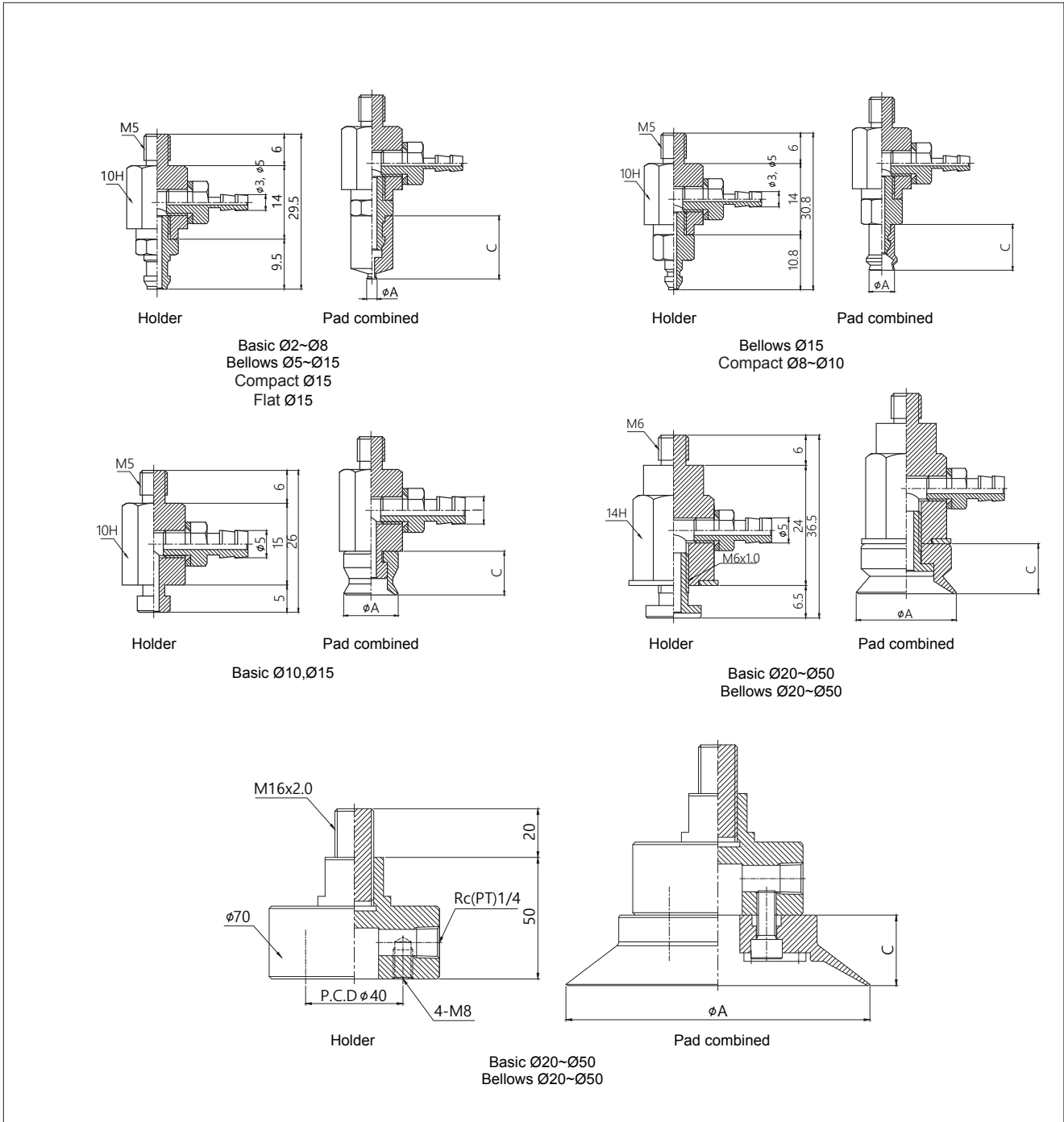

Unit: mm

Pad type		2	4	5	6	8	10	15	20	25	30	40	50	125	160	220
Basic	A	2	4	-	6	8	10	15	20	25	30	40	50	125	160	220
	C	12	12	-	12	12	8	9	10	11	12	14	15	29	31	35
Bellows	A	-	-	5	-	8	10	15	20	25	30	40	50	125	160	220
	C	-	-	9	-	13	15	17	18	20	22	25	28	70	75	80
Flat	A	-	-	-	-	-	-	15	-	-	-	-	-	-	-	-
	C	-	-	-	-	-	-	10.5	-	-	-	-	-	-	-	-
Compact	A	-	-	-	-	8	10	15	-	-	-	-	-	-	-	-
	C	-	-	-	-	7	8	10.5	-	-	-	-	-	-	-	-